



METHOD STATEMENT: MANIPULATION OF FILL FROM A SINGLE STACK S3-D

Scope

Cleaning, removal and/or replacement of the fill in a S3-D single stack unit.

Terminology

- CIS:** Combined Inlet Shield; black plastic honey-comb structure at the air-inlet.
- Fill:** Plastic sheets in the lower section, designed to improve water-air contact.
- A- and B-sheets:** Fill sheets exist in two types. A-sheets hang lower than B-sheets. If the A-sheets are pulled up, they can be nested with the B-sheets.
- Nesting:** To reduce the amount of space, needed by a number of sheets, the fill sheets can be nested. To do this, the spacers on both sheets need to be aligned and inserted in one another.
- Spacers:** Every sheet has several cone shapes, which are called spacers.
- De-nesting:** The opposite of nesting (in operation, the fill-sheets are hanging at a pre-determined spacing).
- Section:** A single stack unit consists out of one section: a lower section, with a fan.
- Bay:** One set of fill sheets is divided in (2), (3) or (4) bays, depending on the width of the unit; (2) bays for a 8.5 feet (2.4m) wide, (3) bays for a 10 feet (3.0m) and 12 feet (3.6m) wide and (4) bays for a 14 feet (4.2m) wide unit.
- Single Stack:** A unit, consisting out of one part which comprises both the sump and the fan is called a single stack unit.
- Double Stack:** A unit, consisting out of two parts, one lower comprising the sump and one upper comprising the fan, is called a double stack unit.

Caution

- It would be wise to have some spare fill-sheets at hand. That way, damaged sheets can immediately be replaced.
- Do not use water, hotter than 50°C, to clean fill. Otherwise the fill-sheets may deform.

General Instructions:

- Always follow applicable site Health and Safety instructions.
- Install relevant safety warning signs/padlocks to alert people of the works taking place
- Take appropriate fire precaution measures when working with components such as fill packs.
- Read operating and maintenance instructions from concerned unit.
- We strongly advise that replacement is executed under BAC supervision.

Crew

- (4) people to replace the fill on one side, estimated work time is (6) to (8) hours, depending on the local site conditions.

Equipment:

- Straps and boards (to 'compress' the fill).
- Safety belts (for units installed at a certain height).
- Set of wrenches and spanners.
- Scaffolding (work platform).
- High pressure cleaner, water & detergents (only to clean the fill, not to replace the fill).

Lay down and work area:

- Make sure enough space is available next to the unit to temporarily store the removed fill sheets (take in account the fill is 1.4m wide and as high as the tower).



A) Provide access to the fill

1. Cut straps securing combined inlet shields (CIS). The straps are only required for transport of the unit (on units with 1 row of CIS per section).
2. Remove the tie rods.
3. Remove the CIS.
4. Remove the CIS-support(s); slide support(s) out but leave the brackets.

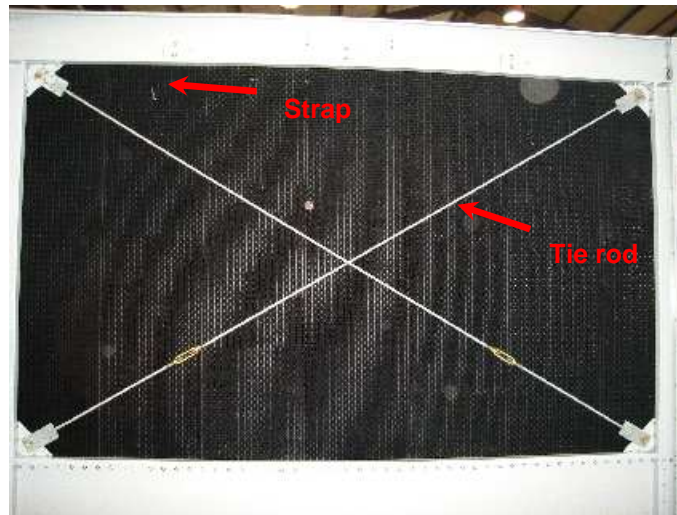

B) Nesting of the fill

The fill is suspended by 4 telescopic fill support pipes; (3) on top and (1) at the bottom (at the air-inlet side). The entire fill-pack is divided in separate bays (2,3 or 4, depending of the width of the unit).

If the tower is equipped with an extra row of drift eliminators, remove them for easier access to the fill from the inside as well.

First, nest the fill sheets from one outer bay. Take the following steps:

1. Insert two boards (one high, one low) between the fill and use straps to compress all but (10) fill sheets for 3 to 4 cm. Be careful not to damage the spacers on the fill sheets.
2. Nest these (10) uncompressed fill sheets, by pulling up the lower hanging A-sheets and pushing them together with the B-sheets.
3. Remove the boards and the straps.
4. Nest the remaining fill sheets of this outer bay.

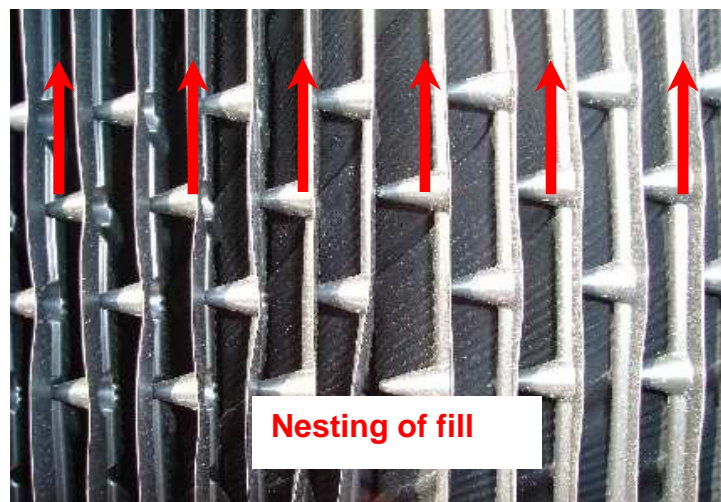
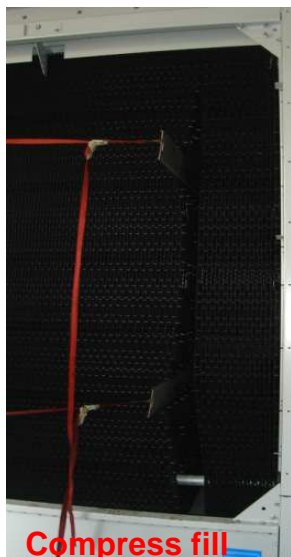



Note: In case a railing is present on top of the unit, the fill sheets can be pulled up from the hatches in the hot water basin. To gain access, remove the knobs and the cover so that the top of the fill is visible through the hatch.

With one of the outer fill bays nested, the rest of the fill bays can easily be nested. This will result in the following view:



C) Cleaning of the fill (if applicable)

Cleaning of the fill is done without removing the fill.

Take the following steps:

1. Slide all the nested sheets together to one side of the bay.
2. Clean the exposed side of one sheet with high pressure cleaner (be careful not to damage the sheets).
3. Slide the sheet over to the other side of the bay.
4. Clean the backside of the sheet and the front side of the next sheet.
5. Repeat for all the sheets. The very first fill sheet (on both sides) is installed behind the Z-profile, but can be cleaned without the Z-profile being removed.
6. De-nest the fill sheets.



D) Remove the fill.

Gain access to the end of the telescopic fill support pipes, by removing the Z-profile with the PVC skirt, gaskets and the last fill sheet behind it.

To reach the telescopic fill supports:

- Upper supports: from the inside or outside of the unit, or through the hatch inside the hot water basin on top of the tower.
- Lower support: from the outside of the unit.

Before the nested fill can be removed, the telescopic fill support pipes must be unlocked (see Figure 1), so that the inner pipe can slide into the outer pipe (see Figure 2).

1. Remove bolt-locking-tappers located at both ends of each fill support pipes (to prevent the bolt from coming horizontal during transport).

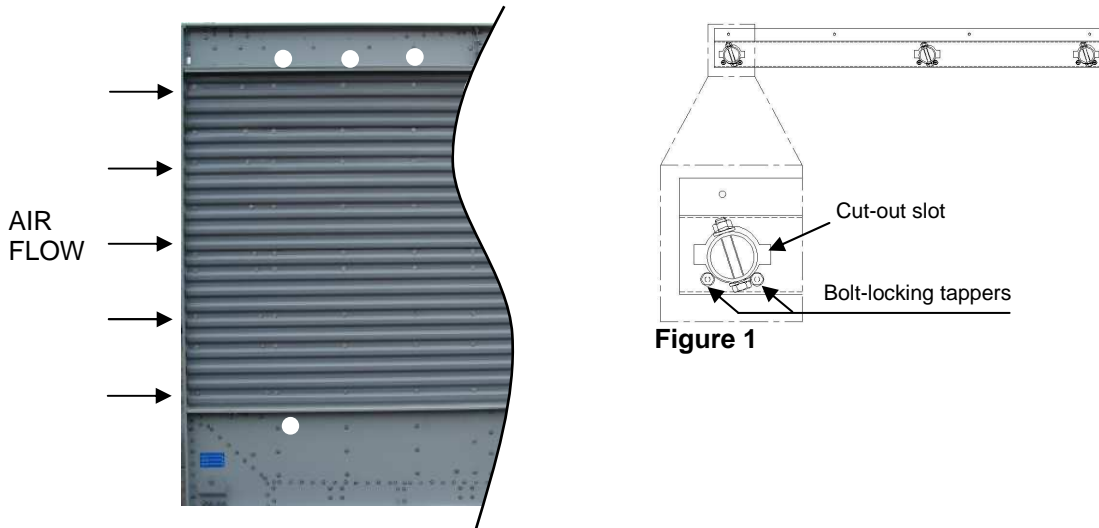

The white dots on the side view of the unit denote the location of the (4) fill supports.

2. Rotate supports to place bolts horizontal (in front of the cut-out slot of Figure 1).

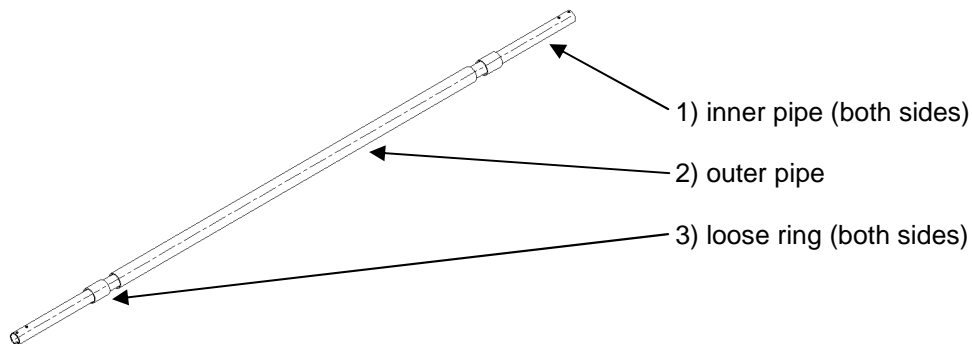

Figure 2

3. Slide inner pipe (1) from the telescopic fill support pipe in the outer pipe (2) (see Figure 2).
4. Remove the nested sheets from the "opened" bay.



5. Remove loose ring (3).
6. Repeat for the other outside bay (keep the sheets from this bay separated from others).
7. Remove the ring from this side as well.
8. If there are 3 bays; slide the outer pipe to one side and remove the sheets from opened bay.
9. If there are 4 bays; slide the outer pipe to the other side so that the fill can be removed and remove the sheets from the 4th bay.

E) Install the new fill

Install the middle bay(s) first, then the outer bays.

1. Put alternating A and B sheets in nested position into a stack of about 10 sheets and hang on the fill supports. See the addendum for the total amount of sheets.
2. Tie the sheets together for easier handling (per 10).
3. Make sure each A-sheet is followed by a B-sheet and vice versa (also for consecutive packages).
4. Put the sheets inside, bottom first and hoist the pack of fill-sheets up.
5. Repeat until all sheets are placed inside the bay.
6. Do the same for the other bays.
7. De-nest as much sheets as possible.
8. If not all the sheets can be de-nested, compress the de-nested sheets with the board and straps, and de-nest the remaining sheets.
9. Remove the boards and straps.
10. Make absolutely sure no sheets remain nested.
11. Count the number of sheets per bay. To avoid loose sheets, exactly the required number of sheets per bay must be installed. See addendum on page 6 and 7.

F) Reinstall the removed parts

1. Install CIS-supports.
2. Place CIS-panels back.
3. Install and tension tie rods, make sure the unit does not 'pull' to one side
4. New straps to hold down the CIS-panels during transport are not necessary.
5. Place the hatch covers back in the hot water basins.



G) Addendum

8.5 feet wide units:

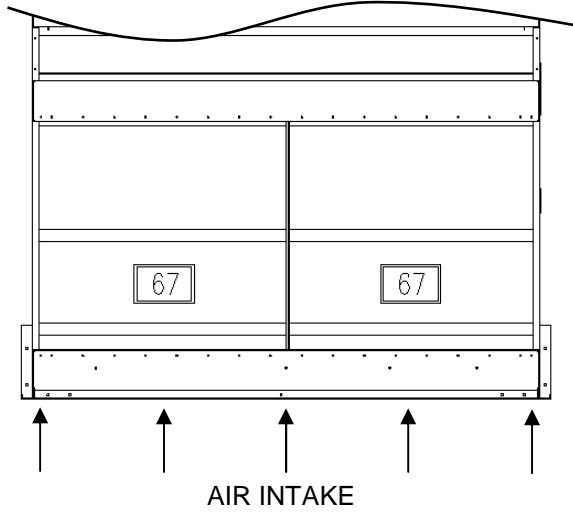

67 sheets per bay, 134 per side, 268 in total (134 A-sheets and 134 B-sheets)

This applies to the following units:

S3-D240
S3-D272

S3-D299
S3-D333

S3-D358
S3-D379

10 feet wide units:

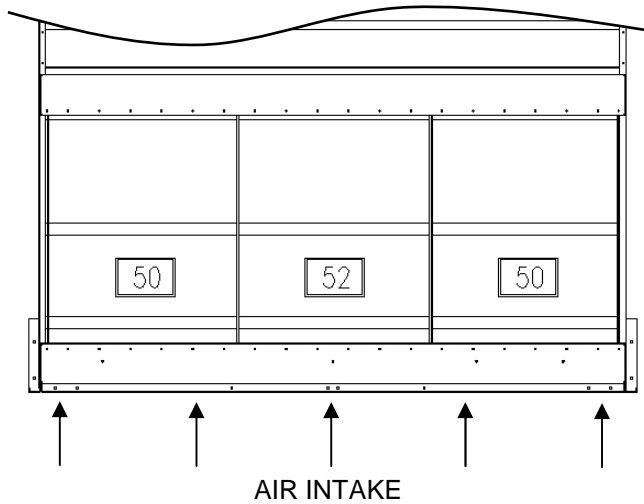

50 or 52 sheets per bay, 152 per side, 304 in total (152 A-sheets and 152 B-sheets)

This applies to the following units:

S3-D412
S3-D436

S3-D455
S3-D482

S3-D527



12 feet wide units:

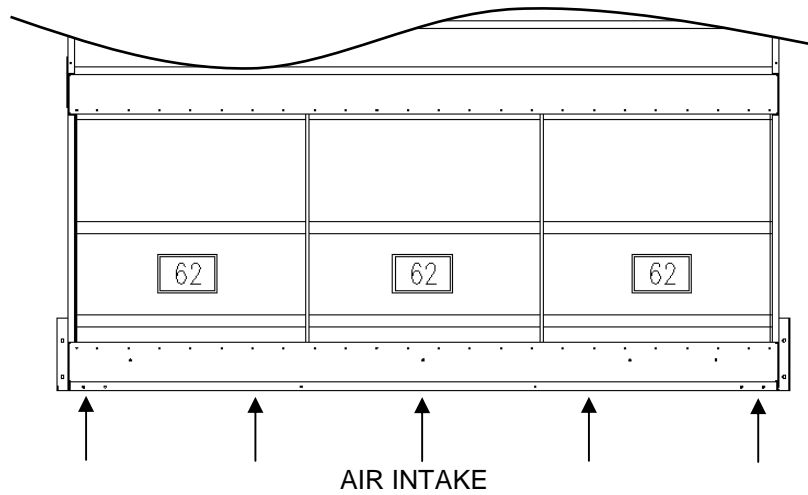

62 sheets per bay, 186 per side per stack, 744 in total (372 A-sheets and 372 B-sheets)
This applies to the following units:

S3-D473
S3-D501

S3-D552
S3-D604

S3-D648
S3-D672

14 feet wide units:

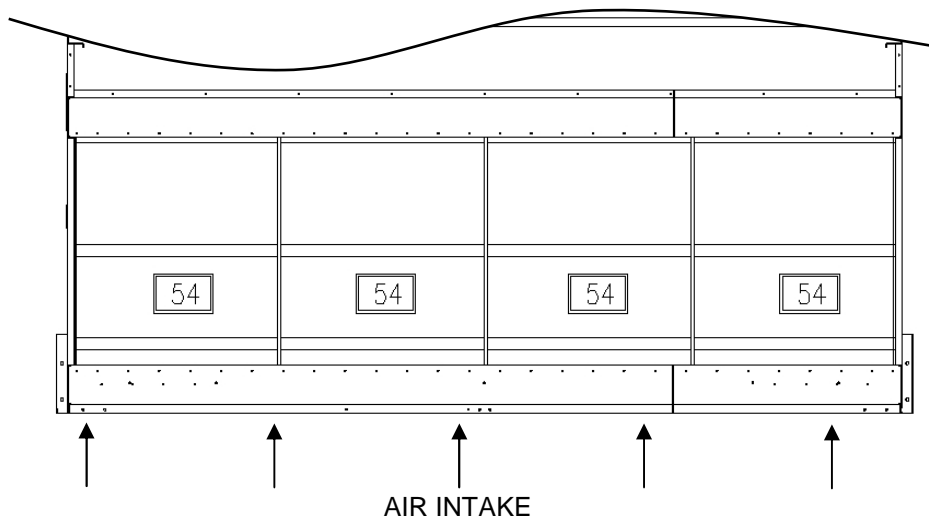

54 sheets per bay, 216 per side per stack, 864 in total (432 A-sheets and 432 B-sheets)
This applies to the following units:

S3-D583
S3-D618

S3-D676
S3-D725