

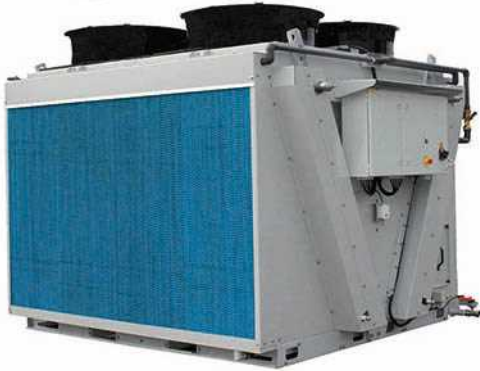

**BALTIMORE
AIRCOIL COMPANY**



TVFC Adiabatic Cooler

RIGGING AND INSTALLATION INSTRUCTIONS

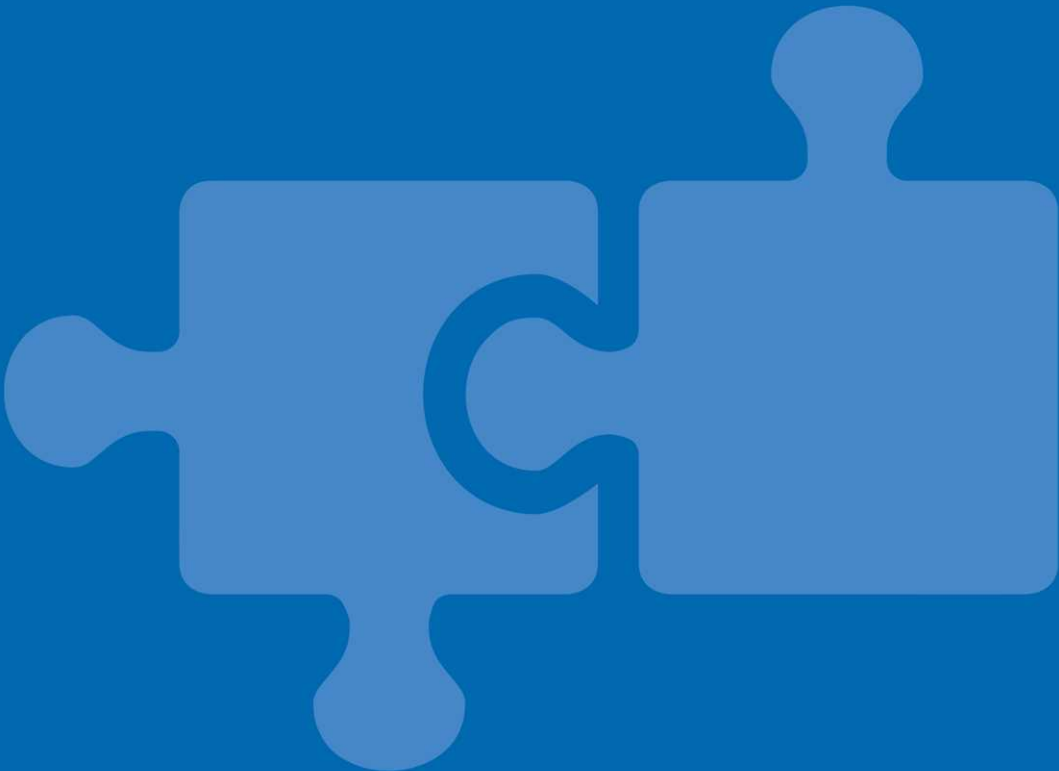



About rigging and installation

The BAC equipment should be rigged and installed as outlined in this bulletin.

These procedures should be thoroughly reviewed prior to the rigging and operation to acquaint all personnel with the procedures to be followed and to assure that all necessary equipment will be available at the job site. Be sure to have a copy of the unit certified drawing available for reference. If you do not have a copy of this drawing or if you need additional information about this unit, contact the local BAC representative. His name and phone number can be found on the www.BaltimoreAircoil.com. The model type and serial number of your equipment are indicated on the unit nameplate.

Recommended maintenance and monitoring programme

Checks and adjustments	Start-Up	Every month	Every 3 months	Every 6 months	Every start of adiabatic season, Spring
Adiabatic pre-cooler water flow	X		X		X
Level switches (optional)	X				X
Tighten electrical connections	X			X	X
Rotation of fan(s)	X				
Motor voltage and current	X			X	X
Unusual noise and/or vibration	X		X		X

Inspections and monitoring	Start-up	Every month	Every 3 months	Every 6 months	Every start of adiabatic season, Spring
General condition of the equipment	X		X		X
Adiabatic pre-cooling pads	X		X		X
Heat transfer coil	X			X	
Water distribution pipe	X			X	X
Float switch (ball can move freely)	X	X			X

Cleaning procedures	Start-up	Every month	Every 3 months	Every 6 months	Every start of adiabatic season, Spring
Adiabatic pre-cooling media	X		X		X
Adiabatic gutter system				X	X
Sump				X	X
Coil (remove dust)					X



Auxiliary equipment integrated in the cooling system may require additions to the table above. Contact suppliers for recommended actions and their required frequency.

Table of contents

RIGGING AND INSTALLATION INSTRUCTIONS



1	General information	4
	About engineering and application practices	4
	Shipping	4
	Inspection before rigging	4
	Unit weights	4
	Anchoring	5
	Leveling	5
	Connecting pipework	5
	Purge requirements	5
	Freeze protection	5
	Safety precautions	6
	Non-walking surfaces	7
	Modifications by others	7
	Warranty	7
2	Rigging	8
	General notes	8
	Removing a unit from a container (container shipment only)	9
	Rigging information	10
	Rigging Method	10
3	Section Assembly	13
	Installation of a "once-through" pre-cooler (Container shipment only)	13
	Installation of a "recirculation" pre-cooler (Container shipment only)	18
	Installation of screw-on flanges	25
4	Optional Accessories Assembly	26
5	Inspection Prior to Start-up	27
	General	27
6	Further Assistance & Information	28
	The service expert for BAC equipment	28
	More information	28

About engineering and application practices

This bulletin only refers to the assembly of the unit. To ensure a proper operation, a correct integration of the unit in the overall installation is mandatory. For good engineering and application practices on layout, levelling, connecting pipework, etc., please refer to our website:

<http://www.baltimoreaircoil.eu/knowledge-center/application-information>.

Shipping

BAC cooling equipment is factory assembled to assure uniform quality and minimum field assembly. The adiabatic pre-cooler sections of the TrilliumSeries™ cooler unit are factory installed at both sides. Only in case of container transport the adiabatic pre-cooler section of one side is shipped separately and needs to be installed on site.

Inspection before rigging

When the unit is delivered to the job site, it should be checked thoroughly to ensure all required items have been received and are free of any shipping damage prior to signing the bill of lading.

The following parts should be inspected:

- Exterior panels and covers
- Fans
- Heat exchanger
- Adiabatic pre-cooler sections
- Electrical panels

In case of container shipment the pre-cooler media, frame panels and pre-cooler water gutter for one side are shipped loose and packed separately in a wooden crate.

Gasket for assembly is already applied on these sections. SST bolts and nuts are packed in a small cardboard box and stored inside the wooden crate of the pre-cooler sections.

Unit weights

Before rigging any BAC equipment, the weight of each section should be verified on the unit certified drawing.



These weights are **approximate** and should be confirmed by weighing **before lifting** when available hoisting capacity provides little margin for safety.



CAUTION

Before an actual lift is undertaken, ensure no water, snow, ice or debris has collected in the sump or elsewhere in or on the unit. Such accumulations will add substantially to the equipment's lifting weight.

In the event of extended lifts or where hazards exist, the lifting devices should be used in conjunction with safety slings placed under the unit.

Anchoring

The unit must be properly anchored in place.

Refer to the suggested support details on the certified drawing for locations of the mounting holes. Anchor bolts must be provided by others.

Holes suitable for 13 mm bolts are provided in the bottom flange of the cooler support structure for bolting the unit to the support beams.

Leveling

The unit must be level for proper operation and ease of piping.

The unit should be level to 0,5 mm/m over the unit length and width.

Support beams must also be level as shims should not be used between pan and support beams to level the unit.

Connecting pipework

All piping external to BAC cooling equipment must be supported separately.

In case the equipment is installed on vibration rails or springs, the piping must contain compensators to eliminate vibrations carried through the external pipework.

Purge requirements

The installer of BAC closed circuit cooling towers must ensure a proper air purging of the system prior to operation.

Entrained air can restrict the capacity of the cooler, resulting in higher process temperatures.

Freeze protection

These products must be protected against damage and/or reduced effectiveness due to possible freeze-up by mechanical and operational methods. Please contact your local BAC representative for recommended protection alternatives.



Safety precautions

All electrical, mechanical and rotating machinery constitutes a potential hazard, particularly for those not familiar with its design, construction and operation. Accordingly, adequate safeguards (including use of protective enclosures where necessary) should be taken with this equipment both to safeguard the public (including minors) from injury and to prevent damage to the equipment, its associated system and the premises.

If there is doubt about safe and proper rigging, installation, operation or maintenance procedures, contact the equipment manufacturer or his representative for advice.

When working on operating equipment, be aware that some parts may have an elevated temperature. Any operations on elevated level have to be executed with extra care to prevent accidents.



CAUTION

Surface of coil/piping can be hot.

AUTHORIZED PERSONNEL

The operation, maintenance and repair of this equipment should be undertaken only by personnel authorized and qualified to do so. All such personnel should be thoroughly familiar with the equipment, the associated systems and controls and the procedures set forth in this and other relevant manuals. Proper care, personal protective equipment, procedures and tools must be used in handling, lifting, installing, operating, maintaining and repairing this equipment to prevent personal injury and/or property damage. Personnel must use personal protective equipment where necessary (gloves, ear plugs, etc...)

MECHANICAL SAFETY

Mechanical safety of the equipment is in accordance with the requirements of the EU machinery directive. Depending upon site conditions it also may be necessary to install items such as bottom screens, ladders, safety cages, stairways, access platforms, handrails and toe boards for the safety and convenience of the authorized service and maintenance personnel.

At no time this equipment should be operated without all fan screens in place and properly secured.

Since the equipment operates at variable speeds, steps must be taken to avoid operating at or near the installation's "critical speed".

For more information consult your local BAC representative.

ELECTRICAL SAFETY

No service work should be performed on or near the fans unless motors are electrically isolated.

FLAMMABLE MATERIAL

The pre-coolers are made of flammable material and should be removed when performing hot works on the unit itself. No actions generating sparks should be performed on or near the unit.

LOCAL REGULATIONS

Installation and operation of cooling equipment may be subject to local regulations, such as establishment of risk analysis. Ensure regulatory requirements are consistently met.



CAUTION

Failure to use designated lifting points can result in a dropped load causing severe injury, death and/or property damage. Lifts must be performed by qualified riggers following BAC published Rigging Instructions and generally accepted lifting practices. The use of supplemental safety slings may also be required if the lift circumstances warrant its use, as determined by the rigging contractor.

Non-walking surfaces

Access to and maintenance of any component needs to be performed in accordance with all local applicable laws and regulations. If the proper and required access means are not present, temporary structures need to be foreseen. Under no circumstance can one use parts of the unit, that are not designed as an access mean, unless measures can be taken to mitigate any risks that might occur from doing so.

Modifications by others

Whenever modifications or changes are made by others to the BAC equipment without written permission of BAC, the party who has done the modification becomes responsible for all consequences of this change and BAC declines all liability for the product.

Warranty

BAC will guarantee all products to be free from manufactured defects in materials and workmanship for a period of 24 months from the date of shipment. In the event of any such defect, BAC will repair or provide a replacement. For more details, please refer to the Limitation of Warranties applicable to and in effect at the time of the sale/purchase of these products. You can find these terms and conditions on the reverse side of your order acknowledgement form and your invoice.

General notes

1. The equipment arrives on site by truck.
A crane must always be used to unload the unit from the truck. Do not attempt to unload the unit using a forklift.
2. If the unit is shipped in a closed box container, one side of the pre-cooling media construction is shipped separately in the container and needs to be installed on site.
3. Spreader bars of the full width of the section must be used between the lifting cables to prevent damage to the section.
4. For extended lifts or where hazards exist, it is recommended to use the lifting devices in conjunction with safety slings placed under the unit.
5. For each unit, only one lift is required. Lifting ears are foreseen on each unit.



Use shackles in lifting ears to lift the unit

6. Attach the lifting devices to the unit as per rigging methods below. Unload the unit from the truck.
7. Install the unit in its final position and anchor to the support beams (supplied by others).



CAUTION

When the unit is installed, all metal parts created by drilling, fastening self tapping screws, grinding, welding or other mechanical works must be removed from the unit. If they remain on the unit (typically on the double break flanges) this could lead to corrosion and eventually coating damage.



CAUTION

Before an actual lift is undertaken, ensure no water, snow, ice or debris has collected in the unit. Such accumulations will add substantially to the equipment's lifting weight.

Removing a unit from a container (container shipment only)

1. Open the container, remove all parts in front of the unit.
2. Attach chains to the bottom of the unit.



Remove unit out of container

3. Pull the unit out of the container to about +/-1 m with a forklift that can handle at least half the shipping weight of the unit.
4. Shorten the chains to the point the unit rests on the forks.
5. Continue pulling the unit out of the container up until the point the 2 fork lift pockets are visible.
6. Put a 2nd forklift underneath the wooden skid (do not use the fork lift pockets). The forks need to be at least 2.4 m long in order to be able to support the unit across it's full width.
7. Lift the unit slightly with the 2nd forklift, move the truck forwards, remove the chains and move the 1st fork lift backwards.
8. Place the unit on the ground in a clear and level area.

9. Remove the bolts holding the unit to the skid and lift it into place in accordance with the proper rigging method.

Rigging information

Model	Width "W" mm	Length "L" mm	Height for slings "H" mm
4-Fan	2400	2400	2100
6-Fan	2400	3600	2100
8-Fan	2400	4800	2100
10-Fan	2400	6000	2100
12-Fan	2400	7200	2100
14-Fan	2400	8400	2100

Rigging Method

RIGGING METHOD

To avoid damage during hoisting, a spreader beam should be used and the angles shown in the diagrams below must be observed.

End View

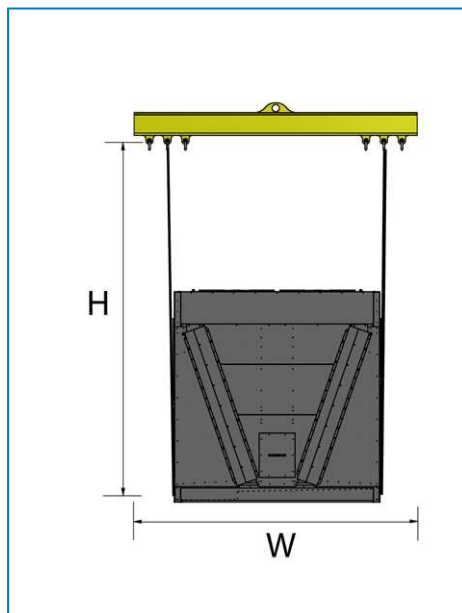

End view

Side View

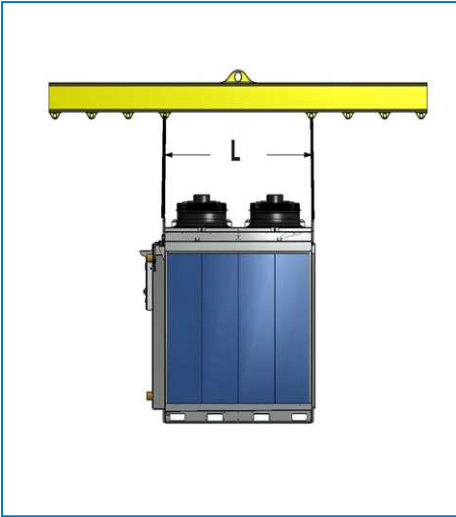

4-fan units

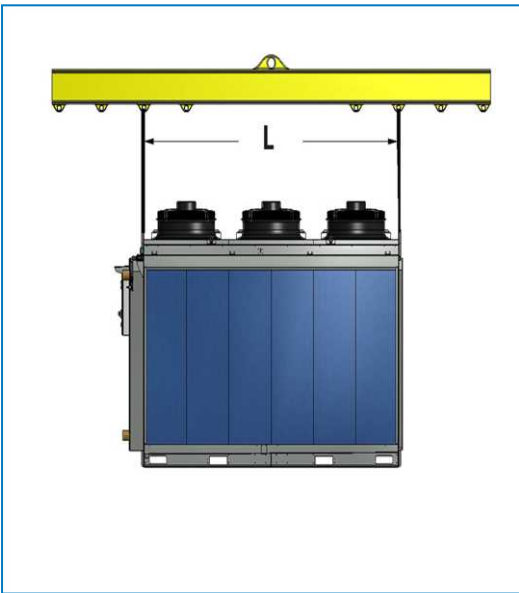

6-fan units

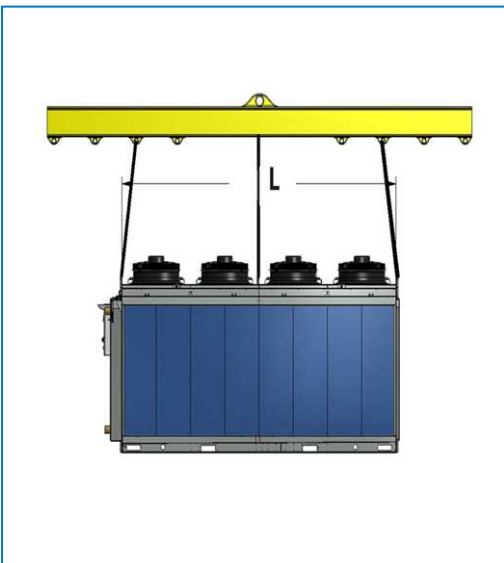

8-fan units



10-fan units

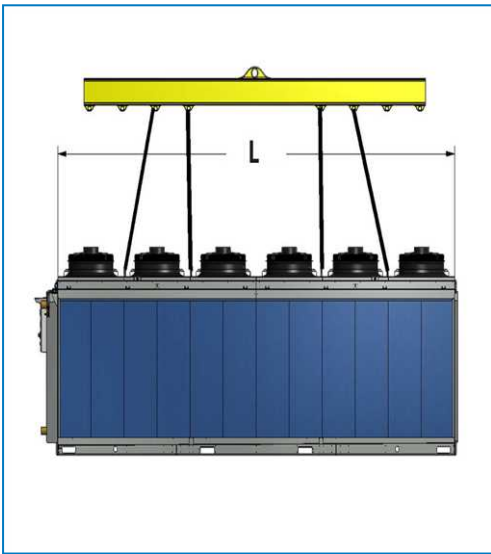

12-fan units

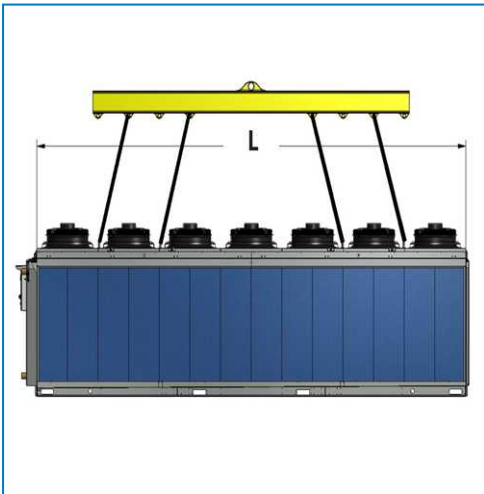

14-fan units

3

TVFC SECTION ASSEMBLY

Installation of a "once-through" pre-cooler (Container shipment only)

GENERAL NOTES

1. If a unit has to be shipped inside a container, the 2nd pre-cooler frame is shipped loose and packed separately in a crate.
2. This crate, with the parts to assemble this frame, is located in the 1st pre-cooler.
3. The pads are shipped loose inside the container and need to be stored in a shielded area in order to protect them from damage during transport until they can be installed in the mounted pre-cooler frame.
4. Remove the crate from the unit by loosening the bolts at the side of the unit.

PRE-COOLER ASSEMBLY

1. Install the side panels of the frame.

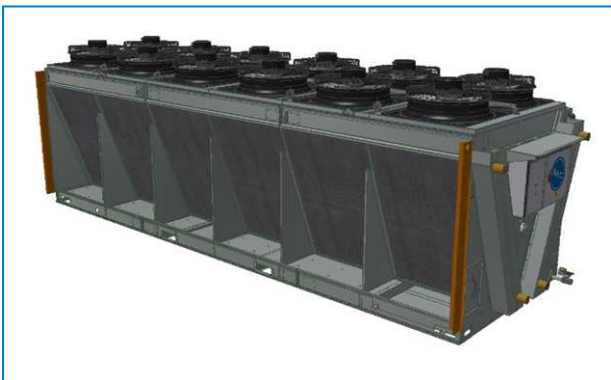

2. Install the water distribution pipe supports at the top of the unit.



3. Install the pipe clamps on the pipe supports.

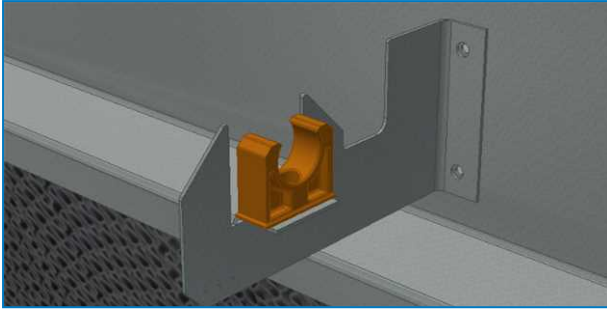

4. Take the top panel, install the L-shaped hook supports at the back and place the hook through the slot (the flange at the bottom of the top panel faces forward). Fasten the bolt but not too tight, so that the hook can still rotate freely.

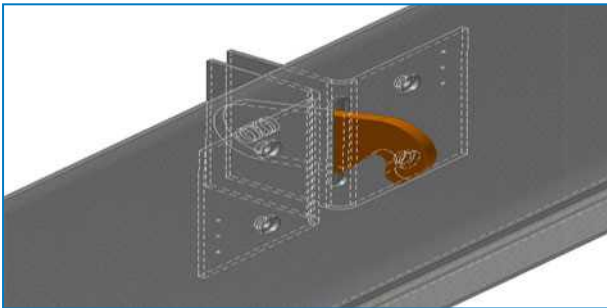

5. Install the top panel on the pipe supports.

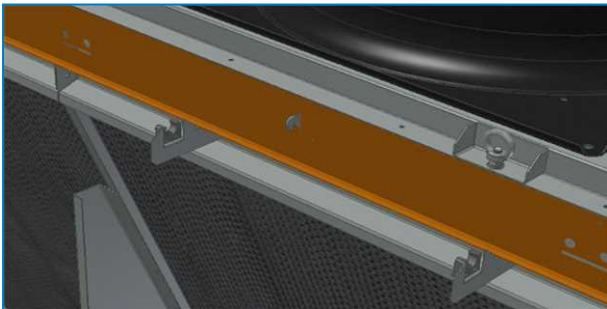

6. Install the hinges on the top panel.

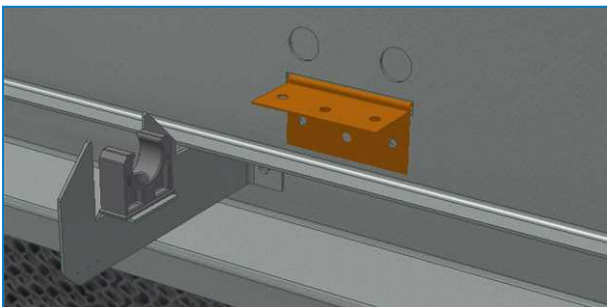

7. Install the water distribution pipe in the pipe clamps with the holes facing upwards and the threaded connection at the side with the electrical panel. On long units, multiple pipes need to be joined together with a rubber sleeve.

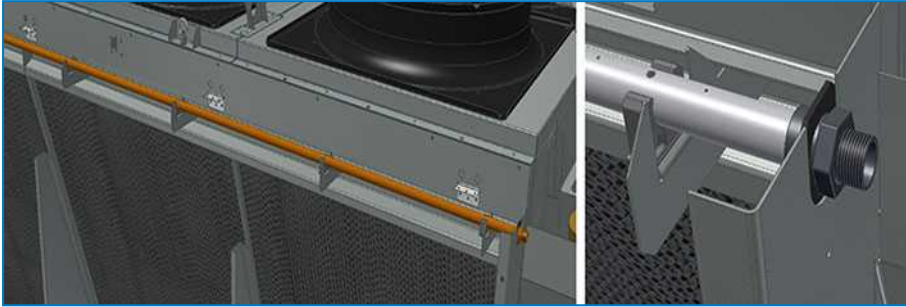

8. Apply PTFE tape to the threaded connection and screw the pipe into the city water piping assembly, click the solenoid on the valve.

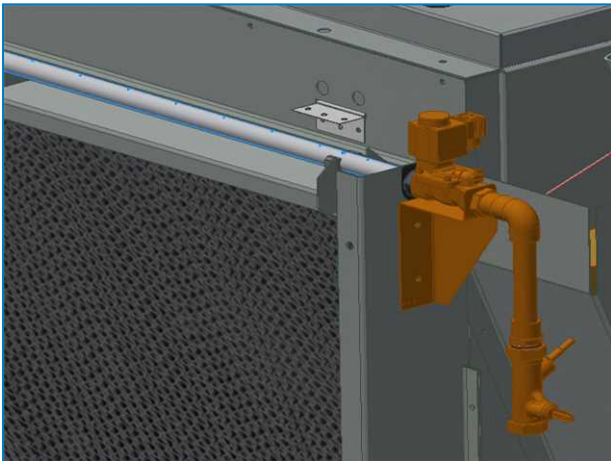

9. With the holes on the pipe still facing upwards, place an M5x50 bolt through the branches and the clamps with a seal washer at the top and both a flat washer and lock washer at the bottom.

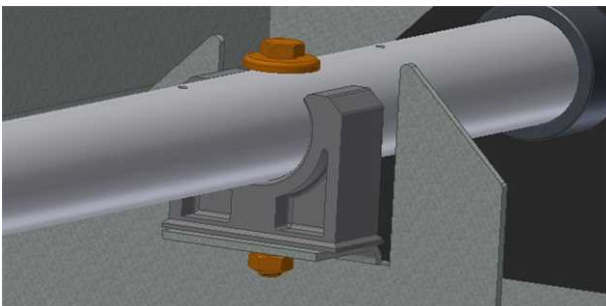

10. Place the distribution deflectors on top of the supports, move the rubbers against the side panels for a proper seal.

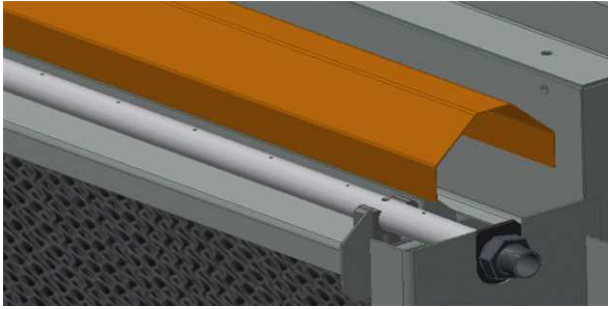

11. In case of a split top cover (TVFC EC 8024, TVFC EC 8025, TVFC EC 8026 or TVFC EC 8027) install 2 supports on the middle deflector, as shown below.

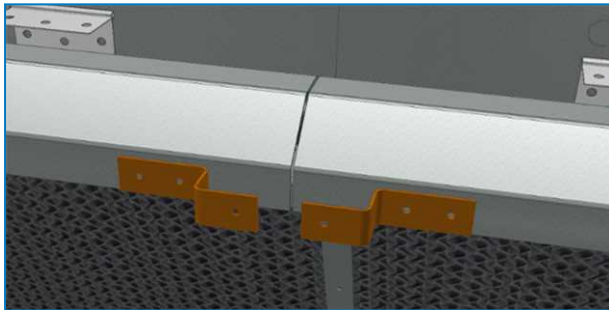

12. Attach the top cover to the different hinges.

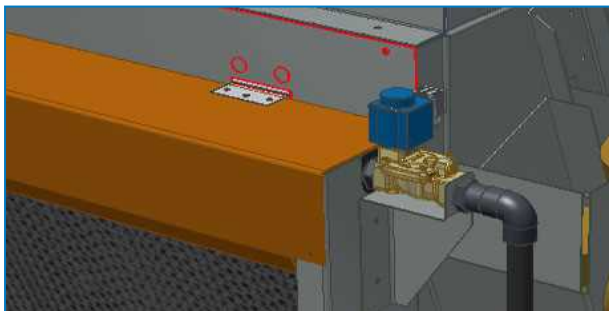

13. In case of a bottom water collection gutter out of multiple parts, join them together with the clip and rivets after putting liquid sealant on the clip.

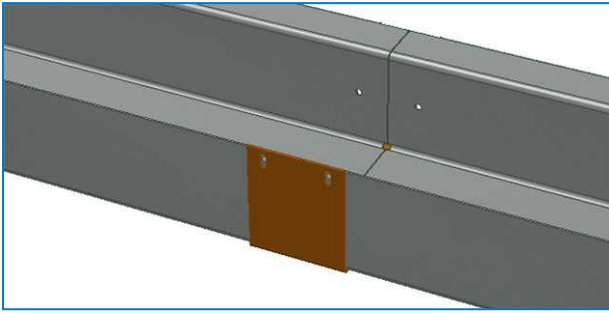

14. Install the bottom water collection gutter over the frame.

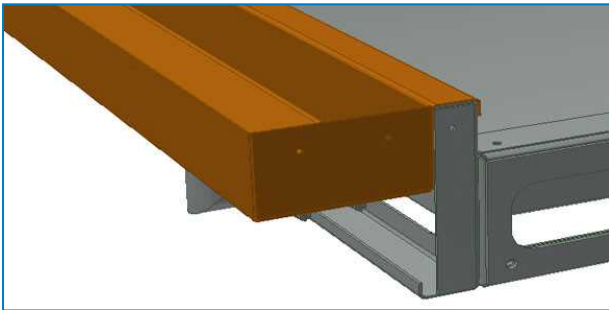

15. Caulk the sides and fasten with screws.

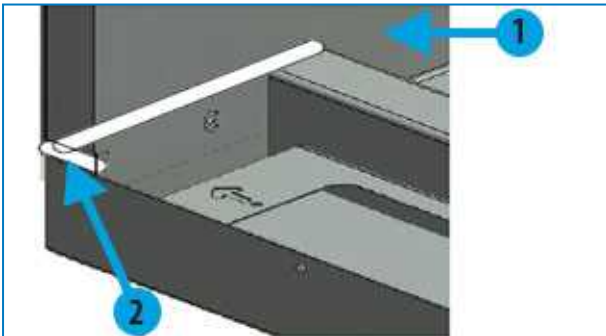

1. Corner coil support
2. Caulk corner (typ.)

16. Install the pad supports with the arrow pointing in the direction of the water flow. The support with one dot at the base of the arrow is installed at the drain, any additional support will have 2 or 3 dots and need to be installed in that order.

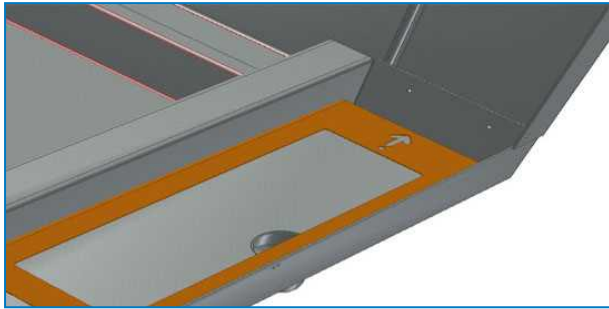

17. Install the pads in both pre-coolers with the blue colour at the outside and the pre-glued distribution pad (not coloured) at the top.

Installation of a "recirculation" pre-cooler (Container shipment only)

GENERAL NOTES

1. If a unit has to be shipped inside a container, the 2nd pre-cooler frame is shipped loose and packed separately in a crate.
2. This crate, with the parts to assemble this frame, is located in the 1st pre-cooler.
3. The pads are shipped loose inside the container and need to be stored in a shielded area in order to protect them from damage during transport until they can be installed in the mounted pre-cooler frame.
4. Remove the crate from the unit by loosening the bolts at the side of the unit.

PRE-COOLER ASSEMBLY

1. Install the side panels of the frame.

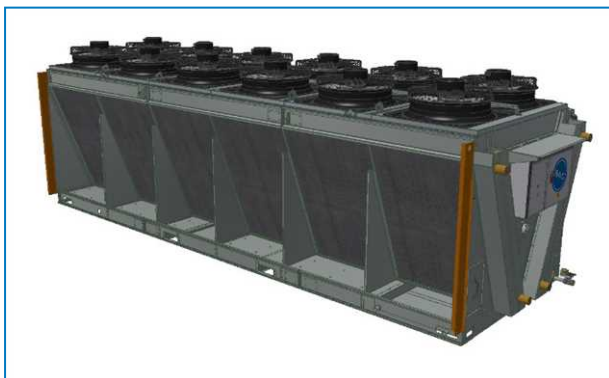

2. In case of a top water distribution gutter consisting out of multiple parts, join these together with M8x25 SST bolts after applying sealer at the flanges. Cut away excess sealer that is pushed out of the flanges.

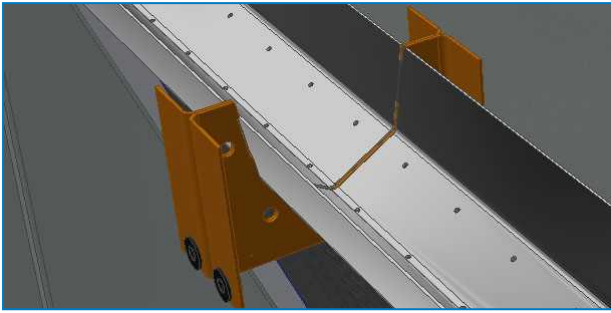

3. Install top water distribution gutter between the side panels with the tallest side facing the coil.

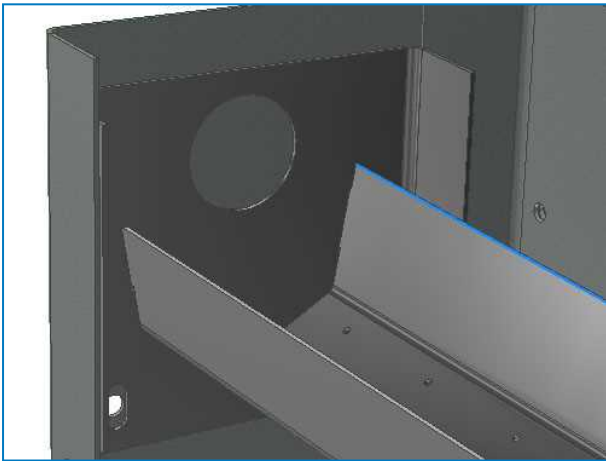

4. Attach the gutter to the intermediary supports.

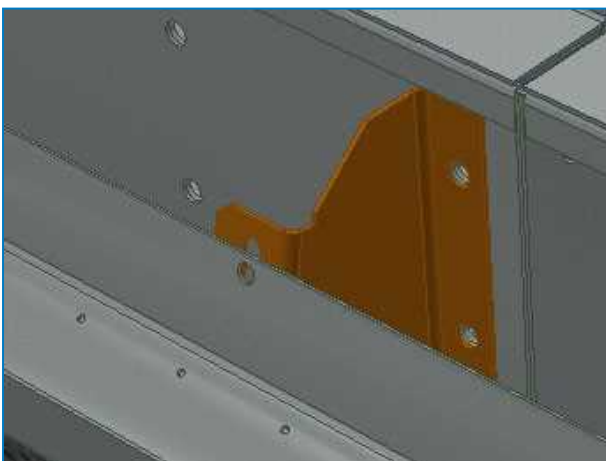

5. Make sure the gutter is installed level and adjust as necessary for a proper water distribution.

6. Install the make-up box at the top panel on the side, opposite of the water collection sump.

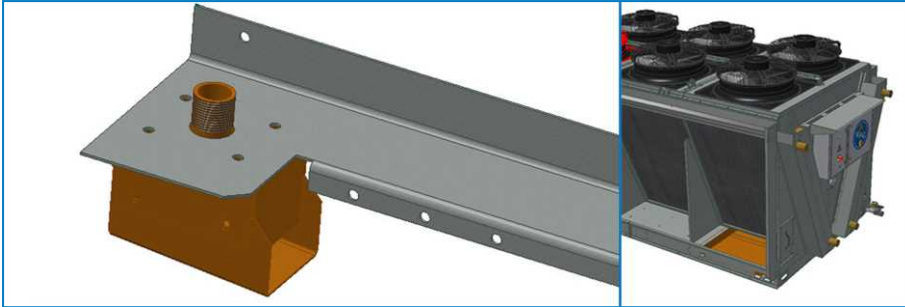

7. Install a closure plate on the other side.

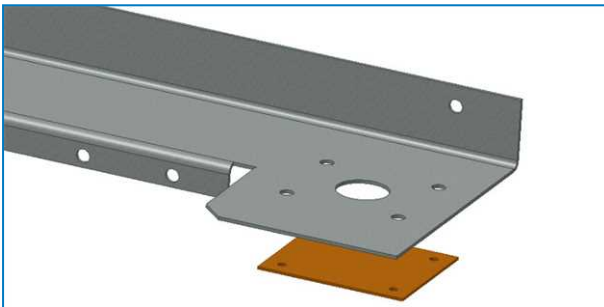

8. Install the end of the make-up piping to the make-up box.

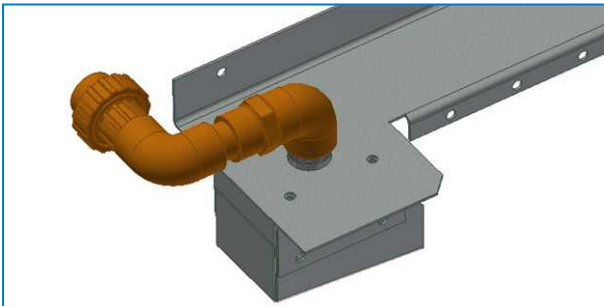

9. Install the top panel on the unit.

10. Connect the make-up valve assembly to the pre-cooler make-up box with the PVC pipe.



11. Install rear cover on the make-up box and fix into place with a taper in the middle hole.

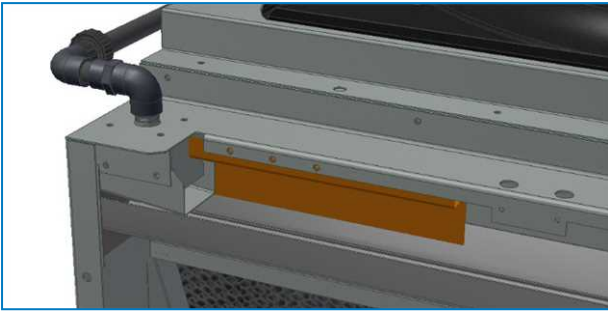

12. Install the front cover on the make-up box and fix into place with tappers in the adjacent holes.

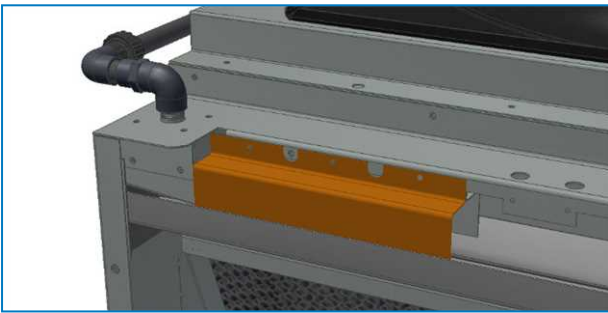

13. Install the rear cover on the other side and fix into place with a taper in the middle hole.

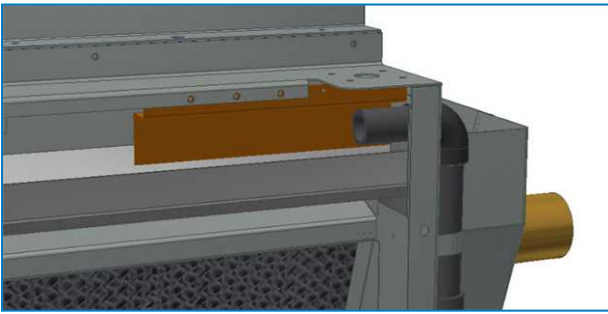

14. Install the last front cover and fix into place with tappers in the adjacent holes.

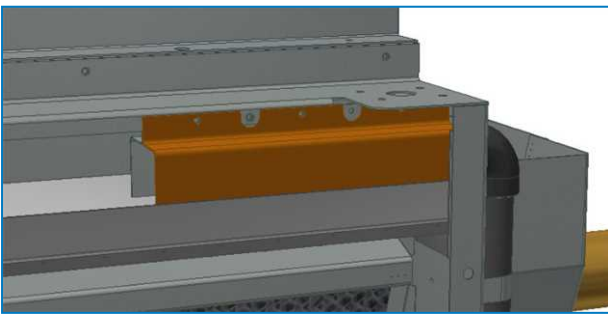

15. Install the hinges on the top panel.

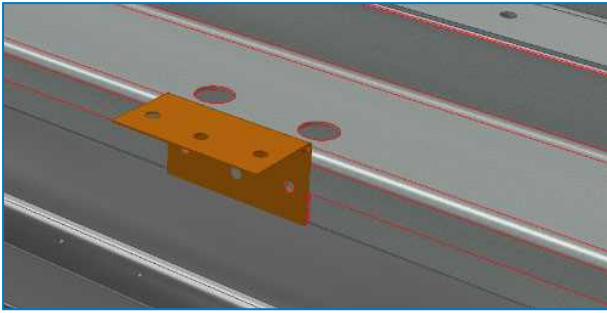

16. Attach the top cover to the different hinges.

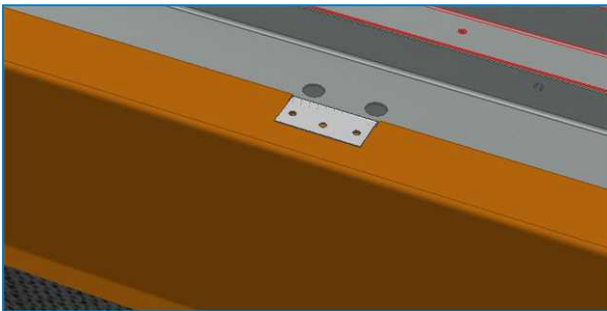

17. For a unit with a single pump, connect the pump discharge pipe to the top water distribution gutter. Tighten the screw connection at the outside and the PVC nut at the inside.

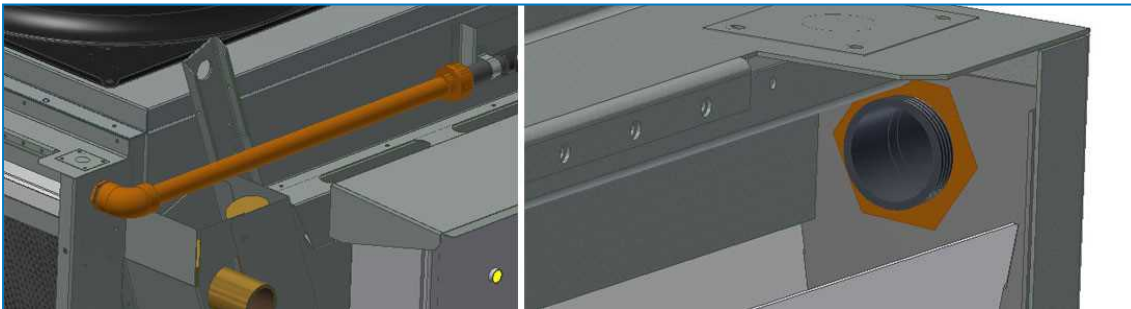

18. For a unit with 2 pumps, install the pre-assembled piece of piping at the outside and fix into place with the strap. Place the elbow at the back and connect the pump discharge line.

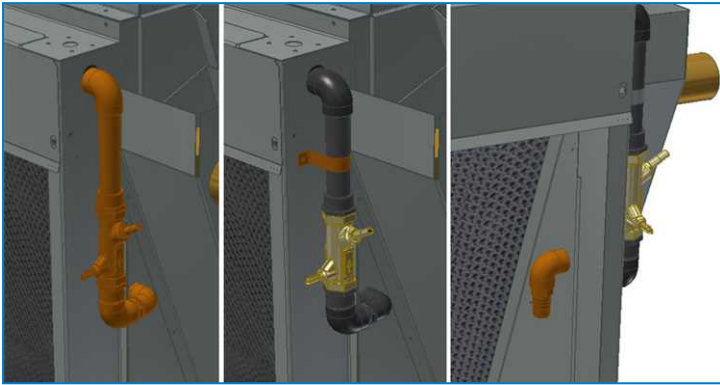

19. Slide the rubber sleeve with clamps over the bottom water collection gutter drain.

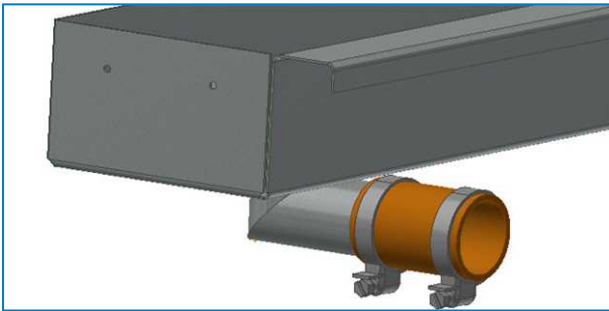

20. In case of a bottom water collection gutter out of multiple parts, join them together with the clip and rivets after putting liquid sealant on the clip.

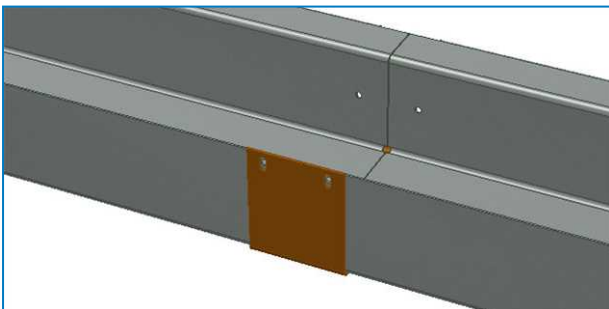

21. Install the bottom water collection gutter over the frame.

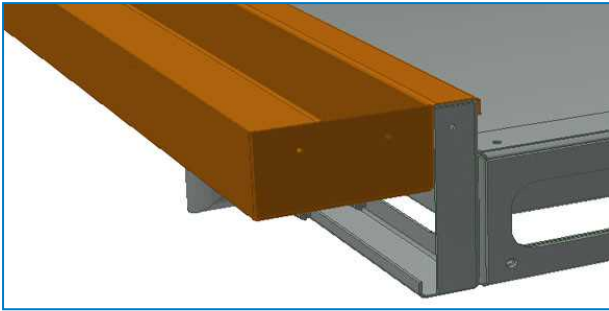

22. Caulk the sides and fasten with screws.

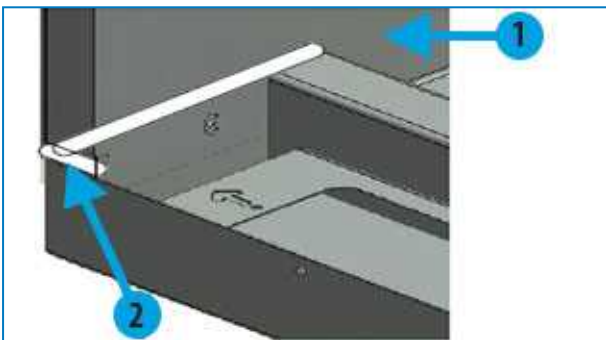

1. Corner coil support
2. Caulk corner (typ.)

23. Install the pad supports with the arrow pointing in the direction of the water flow. The support with one dot at the base of the arrow is installed at the drain, any additional support will have 2 or 3 dots and need to be installed in that order.

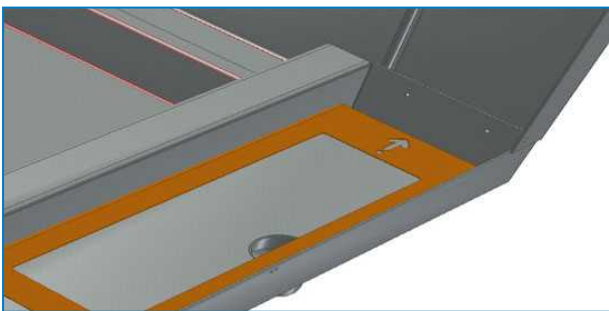

24. Slide the sleeve over the sump connection and tighten the clamps.

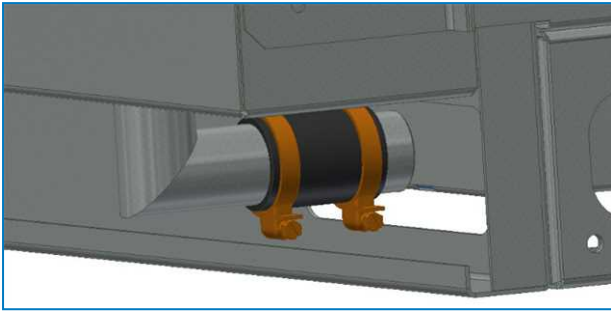

25. Install the pads in both pre-coolers with the blue color at the outside and the pre-glued distribution pad (not colored) at the top.

Installation of screw-on flanges

Care must be taken when installing screw-on flanges on the fluid-connections of the unit to make sure no forces are transferred from the flange to the copper header of the unit. These forces may damage the header and result in coil leaks. Apply the proper opposite force by means of a chain pipe wrench, as shown in the following picture to make sure no force is put on the copper tubes.

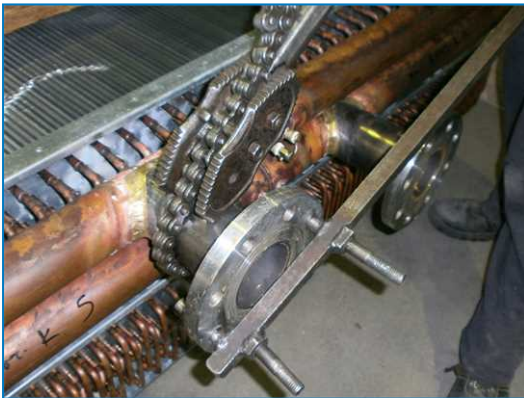

Installing screw-on flange



TVFC OPTIONAL ACCESSORIES ASSEMBLY

All optional accessories are factory installed.



TVFC

INSPECTION PRIOR TO START-UP

General

Prior to start-up, the following services, which are described in detail in the Operating and Maintenance Manual (see table "Recommended maintenance and monitoring programme") must be performed.

Proper start-up procedures and scheduled periodic maintenance will prolong the life of the equipment and ensure trouble-free performance for which the unit is designed.

The service expert for BAC equipment

We offer tailored services and solution for BAC cooling towers and equipment.

- Original spare parts and fill -for an efficient, safe and year round reliable operation.
- Service solutions - preventive maintenance, repairs, refurbishments, cleaning and disinfection for reliable trouble-free operation.
- Upgrades and new technologies - save up energy and improve maintenance by upgrading your system.
- Water treatment solutions - equipment for controlling corrosion scaling and proliferation of bacteria.

For more details, contact your local BAC representative for further information and specific assistance at www.BACservice.eu

More information

REFERENCE LITERATURE

- Eurovent 9-5 (6) Recommended Code of Practice to keep your Cooling System efficient and safe. Eurovent/Cecomaf, 2002, 30p.
- Guide des Bonnes Pratiques, Legionella et Tours Aéroréfrigérantes. Ministères de l'Emploi et de la Solidarité, Ministère de l'Economie des Finances et de l'Industrie, Ministère de l'Environnement, Juin 2001, 54p.
- Voorkom Legionellose. Ministerie van de Vlaamse Gemeenschap. December 2002, 77p.
- Legionnaires' Disease. The Control of Legionella Bacteria in Water Systems. Health & Safety Commission. 2000, 62p.
- Hygienische Anforderungen an raumluftechnische Anlagen. VDI 6022.

INTERESTING WEBSITES

Baltimore Aircoil Company	www.BaltimoreAircoil.com
BAC Service website	www.BACservice.eu
Eurovent	www.eurovent-certification.com
European Working Group on Legionella Infections (EWGLI)	EWGLI
ASHRAE	www.ashrae.org
Uniclîma	www.uniclîma.fr
Association des Ingénieurs et techniciens en Climatique, Ventilation et Froid	www.aicvf.org
Health and Safety Executive	www.hse.gov.uk

ORIGINAL DOCUMENTATION



This manual is originally made in English. Translations are provided for your convenience. In the event of discrepancies, the English original text shall prevail over the translation.



A series of horizontal dotted lines for writing, spanning the width of the page.



A series of horizontal dotted lines spanning the width of the page, providing a template for writing or data entry.





A series of horizontal dotted lines for writing, spanning the width of the page.

COOLING TOWERS

CLOSED CIRCUIT COOLING TOWERS

ICE THERMAL STORAGE

EVAPORATIVE CONDENSERS

HYBRID PRODUCTS

PARTS, EQUIPMENTS & SERVICES

BLUE by nature
GREEN at heart



www.BaltimoreAircoil.com

Europe@BaltimoreAircoil.com

Please refer to our website for local contact details.

Industriepark - Zone A, B-2220 Heist-op-den-Berg, Belgium

© Baltimore Aircoil International nv