

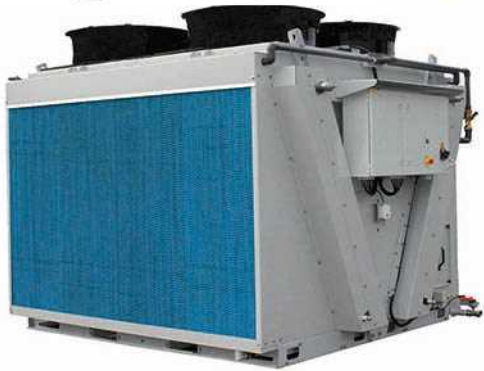

**BALTIMORE
AIRCOIL COMPANY**



TVC Adiabatic Condenser Once Through Mode

SOFTWARE INSTRUCTIONS

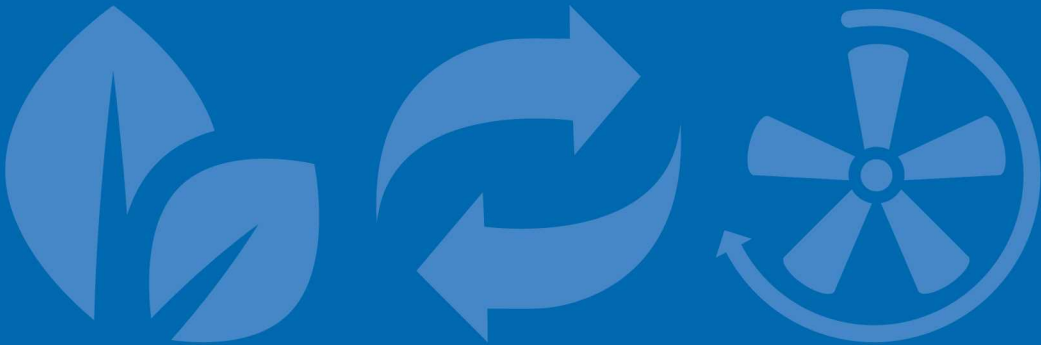



Table of contents

SOFTWARE INSTRUCTIONS

1	Scope	3
	Once Through execution	3
2	Control Logic	4
3	Programmable logic controller	5
	Programmable Logic Controller (PLC)	5
	Display and operations	5
4	Software	7
	Menu overview	7
	Main Loop Menu (P)	8
	User Menu (E)	9
	Working Time Menu (T)	13
	Inputs Outputs Menu (I)	14
	Clock Menu (K)	15
	Logger Menu (H)	15
	System Information (S)	16
	Maintenance Menu (M)	16
5	Alarms and Warnings overview	18
	Alarms overview	18
6	BMS Communication	20
	Available communication protocols and communication cards	20
	Communication table for Bacnet MS/TP	21
7	Further Assistance & Information	25
	More information	25
	The service expert for BAC equipment	25

This manual applies to units configured in Once-Through mode operating on BAC software version V2.0.15 or later, in stand-alone mode.

Once Through execution

The TVC is a V-shaped dry condenser equipped with **adiabatic pre-coolers (1)**. **Water flows (3)** evenly over evaporative cooling pads located in front of the **dry finned coil (4)**. At the same time **axial (5) fans** draw **air (6)** through the pads where a portion of the water evaporates and cools down the saturated air. This increases the cooling capacity of the incoming air for cooling the process **fluid (7)** inside the coil.

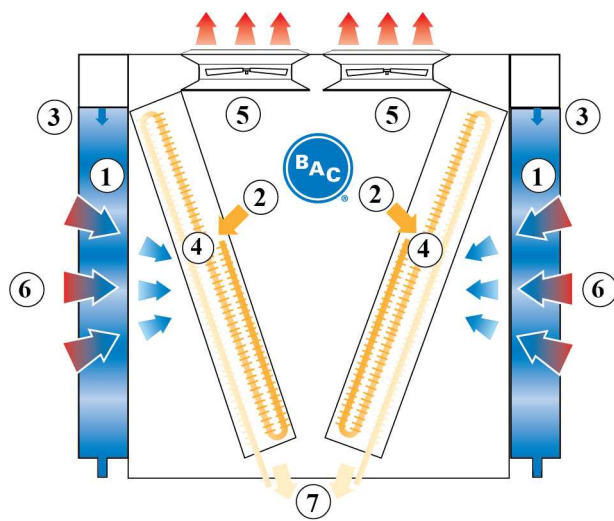



TVC

CONTROL LOGIC

The controller controls the fan speed based on the actual fluid outlet temperature and the standard or free-cooling set point, ensuring a minimum electrical consumption and noise level.

The controller will activate and deactivate the adiabatic pre-coolers, one by one, based on a logical combination of fan speed and two ambient temperature switch points.

tamb: ambient temperature

SWP1, SWP2: ambient temperature switchpoints

CWV: adiabatic pre-cooler city water valve

DV: adiabatic pre-cooler drain valve

The standard set point, the free-cooling set point and the two ambient temperature set points are adjustable via the User menu. The controller continuously measures the fluid outlet temperature via a temperature sensor installed in the fluid out pipe and the ambient temperature via a temperature sensor that is factory installed on the unit.

The controller is pre-programmed and ready for operation. However, depending on the size of the installation, you may need to adjust the pre-programmed parameters during start-up.

Programmable Logic Controller (PLC)

The PLC with built-in display:







Display and operations

The controller display contains the screen and six operation keys.

The screen allows eight lines of text. The screen title and the screen reference are always on the top line.

Use the operation keys to navigate between the different menus and screens.

	<p>Alarm key</p>	<p>Display the alarm menu.</p>
	<p>Menu key</p>	<p>Display the main menu screen.</p>

	Back key	Revert to the previous step or menu.
	Arrow keys	Navigate between the different screens and menus.
	Enter key	Select the marked menu or parameter or enable the change of a parameter.



Menu overview

Menu	Screen reference	Function
Main loop	P	Readout: <ul style="list-style-type: none">- The unit status (ON/OFF)- The condenser pressure and ambient temperature- The fan speed- The pre-cooler status
User	E	Set: <ul style="list-style-type: none">- Run authorisation / local ON/OFF- Standard and free-cooling set-point- PI parameters- Ambient temperature switch point for Adiabatic pre-cooling- Adiabatic pre-cooler delay- Adiabatic pre-cooler cleaning cycle- Night quiet mode- Time delay on alarm messages- BMS communication settings The standard password for the User Menu is "1234".
Manufacturer	C	This menu is password protected and is not accessible to unauthorized personnel.
Working time	T	Readout the operating hours for the fans and adiabatic pre-cooling.
Inputs/outputs:	I	Readout the input and output status.
Clock	K	Set the correct time and date.
Logger	H	Readout the alarm and warning history.
System info	S	Readout the software and bios version.
Maintenance	M	Set the inputs and outputs manually for test purposes. The standard password for the Maintenance menu is "9876".

Main Loop Menu (P)



The screens in the Main Loop Menu are read-only and cannot be edited.

Screen P01

```

10:50 23/11/18 P01
BACH1800000 01 Ad:1
Setpoint 06.0bar
Pout 03.1bar
Tamb 33.1°C
Fan speed 000.0%
ON
  
```

Main screen with general information:

- The current time and date.
- The unit serial number and pLAN address: “**Ad: 0**”.
- “**Setpoint**”: the active setpoint for the condenser pressure.
- “**Pout**”: the measured condenser pressure.
- “**Tamb**”: the measured ambient temperature.
- “**Fan speed**”: the current fan speed.
- The unit status: “**ON**” or “**OFF**”.

Note

Unit status ON implies that the unit is ready to automatically respond to any heat rejection requirement, even in case the fans are temporarily deactivated due to the absence of a heat load.

Screen P03

```

Inputs P03
Pout 003.1bar
Tamb 033.1°C
Control signal 000.0%
Local En/Dis ON
BUS En/Dis ON
  
```

Overview of all inputs:

- “**Pout**”: the measured condenser pressure.
- “**Tamb**”: the measured ambient temperature.
- “**Control signal**”: the calculated fan speed reference.
- “**Local En/Dis**”: the status of the remote start/stop (dry contact between terminals Y4:1-Y4:4).
- “**BUS En/Dis**”: the status of the BMS controlled variable “**Run authorization**” (refer to screen E02).

Screen P04

```

Pre-cooling P04
Pre-cooler A OFF
Pre-cooler B OFF
  
```

Adiabatic pre-cooling status:

- “**Pre-cooler A**”: shows the status of the adiabatic pre-cooler on side A.
- “**Pre-cooler B**”: shows the status of the adiabatic pre-cooler on side B.

Screen P10-P51

```

rcmFo_EBM_fan N°2_P10
Offline      Addr:002
Current speed 0000rpm
Max speed    00000 rpm
Power        00000w
Current      00000 mA
  
```

EC fan information screens:

- The fan status: “**Online**” or “**Offline**” and fan address: “**Addr: 002**”.
- “**Current speed**”: the actual fan speed.
- “**Max speed**”: the maximum allowable fan speed.
- “**Power**”: the actual power of the EC fan.
- “**Current**”: Indication of the internal current measured by the EC fan. In most cases this value is a DC current which is typically around 1.42 times bigger as the actual current, but for specific type of EC fans the AC current could be displayed. For exact evaluation of the fan current please measure the current on the terminal strip using an Amperage meter.

Note

In case an EC fan shows the status “Offline”, check the power supply to the fan and the Modbus communication wiring to the fan.

User Menu (E)



The screens in the User Menu are editable. The standard password is “1234”.

Screen E01

```

Language     E01
Language
French
Site name
BACH1607697 01
  
```

- “**Language**”: set the controller language to English, French, Dutch, Spanish or German.
- “**Site name**”: enter the unit serial number or the site name.

Screen E02

```

Setpoints    E02
Run authorisation ON
Setpoints
Standard     06.0bar
Free cooling  05.0bar
  
```

- “**Run authorization**”: activate or deactivate the unit. This variable can either be set directly in this screen or via a BMS variable (see section 6: BMS communication).
- “**Standard setpoint**”: the default setpoint for the condenser pressure.
- “**Free cooling setpoint**”: the setpoint for the condenser pressure when the unit operates in free cooling mode. Switch over to free cooling mode via a BMS controlled variable or via the dry contact between terminals Y4:2-Y4:4.

Example

*The controller controls the fan speed based on the actual condenser pressure and the standard setpoint when the dry contact between terminals Y4:1-Y4:4 is open.
When the dry contact between terminals Y4:1-Y4:4 is closed, the controller controls the fan speed based on the actual condenser pressure and the free cooling setpoint.*

Screen E03

```

PI control      E03
Prop. Band     : 010bar
Integr. Time   : 060s
  
```

PI-parameters: these parameters determine the unit's reaction speed to changes in fluid outlet temperature.

- “**Prop. Band**”: set the value for the proportional band of the PI controller.
- “**Integr. Time**”: set the value for the integration time of the PI controller.



CAUTION

Changing the PI-Parameters may result in a hunting phenomenon.

Note

Make the unit react faster to changes in fluid outlet temperature by decreasing the proportional band and the integration time, or make the unit react slower by increasing the proportional band and integration time.

Screen E04

```

Cleaning cycle  E04
PAD cleaning:
Active
Interval       : 007days
Duration       : 120 min
start between  : 14H00
                and 18H00
  
```

Cleaning cycle for the adiabatic pre-coolers:

- “**PAD cleaning**”: allows you to enable or disable the cleaning cycle function.
- “**Interval**”: set the period (the number of days the adiabatic pre-cooling has not functioned) after which the cleaning cycle must activate.
- “**Duration**”: set the duration for the pre-cooler cleaning cycle.
- Set the time interval for the start of the cleaning cycle.

Example

The pre-cooler cleaning cycle activates the pre-coolers during 120 minutes when the unit has not operated adiabatically for a period of 7 days. The cleaning cycle starts between 14h00 and 18h00.

Note

The controller automatically disables the cleaning cycle when the ambient temperature is below 4°C.

Screens E05-E06

```

AD switchpoints E05
Switchent.1    25.0°C
Switchent.2    28.0°C
AD ON fan speed 099%
AD OFF fan speed 070%
  
```

```

Pre-cooler delay E06
AD ON delay    0300s
AD OFF delay    0030s
  
```

Adiabatic pre-cooler temperature and fan speed switchpoints and time delays:

- “**AD switchpnt.1**” and “**AD switchpnt.2**”: the temperature switchpoints for the activation of the adiabatic pre-coolers.
- “**AD ON fan speed**” and “**AD OFF fan speed**”: the fan speed switchpoints for the activation and deactivation of the adiabatic pre-coolers.

- “AD ON delay” and “AD OFF delay”: the time delays for the activation and deactivation of the adiabatic pre-coolers.

Example

- The first pre-cooler will activate when the ambient temperature > 25.0°C AND the fan speed > 99%, after a 300 seconds delay.
- The second pre-cooler will activate when the ambient temperature > 28.0°C AND the fan speed > 99% after a 300 seconds delay.
- The first pre-cooler will deactivate when the ambient temperature < 27.9°C OR the fan speed < 70% after a 30 seconds delay.
- The second pre-cooler will deactivate when the ambient temperature > 24.9°C OR the fan speed < 70% after a 30 seconds delay.

Note

The temperature and fan speed switchpoints determine the operating strategy of the unit. High temperature switchpoints combined with high fan speed switchpoints typically result in high water savings on the adiabatic pre-cooling, while lower temperature and fan speed switchpoints typically result in higher electrical energy savings on the EC fans.

Screens E10-E11-E12

<pre>Night Quiet mode E10 Night Quiet Mode OFF Daytime s.limit 100.0% Night s.limit 080.0% Control: Clock</pre>	<pre>DAYTIME E11 MON from00H00 to00H00 TUE from00H00 to00H00 WED from00H00 to00H00 THU from00H00 to00H00 FRI from00H00 to00H00 SAT from00H00 to00H00 SUN from00H00 to00H00</pre>	<pre>Night Quiet mode E12 AD switchpoints in night quiet mode Switchent.1 15.0°C Switchent.2 18.0°C</pre>
---	--	---

Night quiet mode: predefine fan speed limits for both day and night time.

- Enable/Disable the Night quiet mode and choose the maximum allowed fan speed during day and night on screen E10:
 - “Night quiet mode”: “ON” or “OFF”: enable or disable the Night quiet mode.
 - “Daytime speed limit” and “Night time speed limit”: set the maximum allowed fan speed during day and night time.
 - “Control”: choose the activation mode: either via a BMS controlled variable (“via BMS”) or via a predefined time daytime schedule in screen E11 (“Clock”).
 - “Daytime clock” Set up a time schedule for the daytime speed limit in screen E11: Monday to Sunday, start time to end time.



Outside of this time schedule, the night time speed limit will apply.

- “Via BMS”: Use parameter “Night quiet mode day/night time speed limit via BMS” to switch between daytime speed limit and night time speed limit (Refer to the communication tables in Chapter 6).
- Set specific adiabatic pre-cooler switchpoints for Night quiet mode operation in screen E12:
 - “AD switchpnt.1” and “AD switchpnt.2”: specific temperature switchpoints for the activation of the adiabatic pre-coolers when the night time speed limit is active.

Example

The Night quiet mode is enabled, with a daytime speed limit of 80% and a night time speed limit of 50%.

During daytime:

- The first pre-cooler will activate when the ambient temperature > 25.0°C **AND** the fan speed > 79.2% (= 99% x 80%) after a 300 second delay.
- The second pre-cooler will activate when the ambient temperature > 28.0°C **AND** the fan speed > 79.2% after a 300 second delay.
- The first pre-cooler will deactivate when the ambient temperature < 27.9°C **OR** the fan speed < 56% (= 70% x 80%) after a 30 second delay.
- The second pre-cooler will deactivate when the ambient temperature < 24.9°C **OR** the fan speed < 56% after a 30 second delay.

During night time:

- The first pre-cooler will activate when the ambient temperature > 15.0°C **AND** the fan speed > 49.5% (= 99% x 50%) after a 300 second delay.
- The second pre-cooler will activate when the ambient temperature > 18,0°C **AND** the fan speed > 49.5% (= 70% x 80%) after a 300 second delay.
- The first pre-cooler will deactivate when the ambient temperature < 17.9 °C **OR** the fan speed < 35% (= 70% x 50%) after a 30 second delay.
- The second pre-cooler will deactivate when the ambient temperature < 14.9°C **OR** the fan speed < 35% after a 30 second delay.

Screen E14

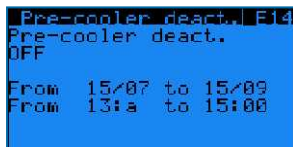

Adiabatic pre-cooling deactivation function:

- “**Pre-cooler deact.**”: enable or disable the pre-cooler deactivation function.
- Set the period and the time frame during which the unit deactivates the adiabatic pre-cooling.

Example

When the pre-cooling deactivation function is active, the adiabatic pre-cooling cannot activate between 13:00 and 15:00 o'clock from 15/07 to 15/09.

Screen E17



Choose the communication protocol: Modbus RS485, Modbus IP, Carel RS485, LON, BacNet IP or BacNet MSTP. Set the communication speed and network address, when applicable. See section 6: BMS communication.

Screen E18

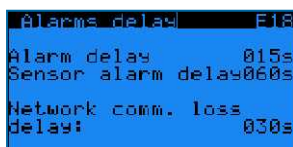

Alarm detection delays:

- “**Alarm delay**”: time delay for EC fan alarms and warnings.
- “**Sensor alarm delay**”: time delay for alarms from the fluid outlet temperature and ambient temperature sensor.

- **“Network comm. Loss delay”**: time delay for the loss of pLAN communication between units (not applicable for stand-alone operation).

Note | *The network communication loss delay is not applicable to stand alone operation.*

Screens E19-E20



EC fan emergency mode management:

Enable the EC fan emergency mode to select a fixed fan speed for when the Modbus communication between the controller and the EC fans fails.

In case the EC fan emergency mode is disabled, the fans will continue to operate at the latest known fan speed when the Modbus communication between the controller and the EC fans fails.

- **“Emergen. mode”**: “ON” or “OFF”: enable or disable the EC fan emergency mode.
- **“Timeout”**: time delay before the EC fan emergency mode activates.
- **“EM speed 1”**: the emergency speed reference in case the ambient temperature \geq the ambient temperature switchpoint.
- **“EM speed 2”**: the emergency speed reference in case the ambient temperature $<$ the ambient temperature switchpoint.
- **“Switch Tamb”**: the ambient temperature switchpoint.

Example | *When the EC fan emergency mode is enabled, EM speed 1 is set to 100%, EM speed 2 is set to 50% and Switch Tamb is set to 15°C, the EC fans will start running at a fixed speed of 100% in case the Modbus communication between the controller and the EC fans fails when the ambient temperature is 20°C.*
In case, the Modbus communication between the controller and the EC fans fails when the ambient temperature is 10°C, the EC fans will start running at a fixed speed of 50%.

Screen E21

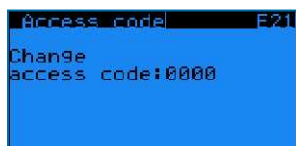

Set your own access code for the User Menu.

Working Time Menu (T)



The screens in the Working Time Menu are read only and cannot be edited.

Screen T02

```

Operating time T02
Fans          000000H
Step 1 AD     000000H
Step 2 AD     000000H
  
```

Read the operating time for the EC fans and for both adiabatic pre-coolers, displayed in hours.

Screen T03

```

Operating time T03
Adiabatic op. 000000H
Dry op.       000000H
  
```

Read the operating time for the EC fans, both adiabatic pre-coolers, and the dry and adiabatic operating time displayed in hours.

Inputs Outputs Menu (I)

The screens in the Inputs/Outputs Menu are read only and cannot be edited.

Screens I01-I02

<pre> Inputs/Outputs I01 U1: T° C Tout 0000.0 °C U2: T° C Tgen 0000.0 °C </pre>	<pre> Inputs/Outputs I02 U3: T° C Tamb 0000.0 °C </pre>
---	--

Read the analog inputs on the controller:

- “**U1: Tout**”: the current condenser pressure.
- “**U2: T° C Tgen**”: not used.
- “**U3: T° C Tamb**”: the current ambient temperature.

Screen I03

```

Inputs/Outputs I03
ID4-DI: Inverter AI  ■
ID5-DI: Free Cooling ■
ID1 : On-Off         ■
U5 : Fan AI         ■
□: open - ■: closed
  
```

Read the status of the digital inputs on the controller (open/closed):

- “**ID4-DI: Inverter AI**”: VFD status (not used in case of unit working with EC fans).
- “**ID5-DI: Free cooling**”: status of the free cooling mode (dry contact between terminals Y4:2-Y4:4).
- “**ID1: On-Off**”: status of the remote start/stop command (dry contact between terminals Y4:1-Y4:4).
- “**U5: Fan AI**”: not used.

Screen I04



Read the status of the digital outputs on the controller (open/closed).

- “**NO8: Alarm(s)**”: closed contact means that there are one or more alarms active.
- “**NO7: Warning(s)**”: a closed contact means that there are one or more warnings active.
- “**NO3: RH Pre-cooler**”: a closed contact means that the right pre-cooler is active.
- “**NO2: LH Pre-cooler**”: a closed contact means that the left pre-cooler is active.
- “**NO5: ---**”: not used.
- “**NO6: Operational**”: run indication, a closed contact means that the fans are running.

Screen I05



Read the analog outputs on the controller:

- “**Y3: N.U**”: not used.
- “**Y4: Fan speed**”: a 0-10 Volt control signal, which corresponds to the actual fan speed.
(0 V = 0%, 10 V = 100%)

Clock Menu (K)



The screen in the Clock Menu is editable.

Screen K01



Set the correct time and date. Time format: HH:MM:SS and date format: DD/MM/YY.

The software automatically adjusts to Daylight Saving Time.

Logger Menu (H)



The screens in the Logger Menu are read only and cannot be edited.

Screen H01



Read the history of past alarms.

The log shows the alarm message and the time the alarm occurred.

System Information (S)



The screens in System Information are read only and cannot be edited.

Screen S01

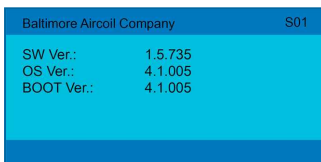

"**SW Ver.**": Current software version installed

"**OS Ver.**": Operating system version

"**BOOT Ver.**": Current boot version

Maintenance Menu (M)

Screen M01



Program a sensor offset ("**Corr. :**") to correct the readings for the condenser pressure sensor ("**Outlet (U1)**") and the ambient temperature sensor ("**Tamb (U3)**").

The general outlet pressure sensor is not used in stand-alone operation.

Screen M02

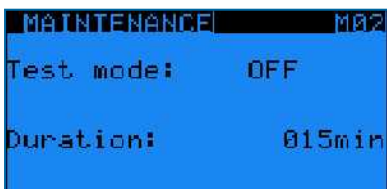

Activate the test mode, which allows to manually set analog and digital outputs and control the EC fans.

- "**Test mode**": activate or deactivate the test mode.
- "**Duration**": time delay after which the test mode automatically deactivates.

Note

1. Duration set to 99 min keeps the test mode ON indefinitely
2. When the test mode is set to OFF, screens M03 to M07 are invisible.

Screen M03

```

Digital override M03
Pre-cooler R (N03): 
Pre-cooler L (N02): 
Run indicat. (N06): 
Alarm (N08): 
Warning (N07): 
: Open / : Closed
  
```

Manually set the digital outputs:

- “**Pre-cooler R**”: activate or deactivate the right hand pre-cooler.
- “**Pre-cooler L**”: activate or deactivate the left hand pre-cooler.
- “**Run indicat.**”: simulate the run indication.
- “**Alarm**”: simulate an alarm.
- “**Warning**”: simulate a warning.

Screen M05

```

Test mode M05
Output override
analog:
Y3:000.0 Volt
Y4:000.0 Volt
  
```

Manually set the analog outputs:

- “**Y3**”: not used for a unit with EC fan motors.
- “**Y4**”: simulate a 0-10 Volt output.

Screen M06

```

Global fan test M06
Fan speed 000.0%
Control type Global
  
```

Manually control the EC fans:

- “**Fan speed**”: 0% to 100%
- “**Control type**”: choose “**Global**” to operate all fans simultaneously at the same speed or choose “**1 by 1**” to set the speed for each fan individually via screen M07.

Screen M07

```

Test indiv. fans M07
N° 2 000.0% N° 9 000.0%
N° 3 000.0% N° 10 000.0%
N° 4 000.0% N° 11 000.0%
N° 5 000.0% N° 12 000.0%
N° 6 000.0% N° 13 000.0%
N° 7 000.0% N° 14 000.0%
N° 8 000.0% N° 15 000.0%
  
```

Set the speed for each fan individually.

Alarms overview

- Access the alarms by pressing the alarm button on the controller (triangle with exclamation mark).
- If a particular alarm is no longer present, the alarm message is automatically cleared and the general alarm (NO1) deactivates.
- To see the history of past alarms, check the logger menu.

Note | *The Alarm status can be read out via dry contact on terminal Y3: 3/4/5 and the warning status on Y3: 1/2 in the control panel.*

Screen AL000

No alarm present.

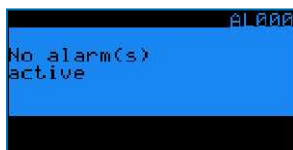

Screen AL001



Condenser pressure sensor (on input U1) is defective.

- Unit stops working.
- Alarm message AL001 on controller display + general alarm (NO1) activates.

Screen AL003



Ambient air temperature sensor (on input U3) is defective.

- Unit remains operational in dry mode, adiabatic operation no longer possible.
- Alarm message AL003 on controller display + general alarm (NO1) activates.

Screens AL010-AL106



Alarms and warnings from the EC fans. Consult BAC factory for more information.

- Unit remains operational, but the defective fan stops working.





BMS COMMUNICATION





Available communication protocols and communication cards

The following communication protocols are available: Carel RS485, Modbus RS485, Modbus TCP/IP, Bacnet IP, Bacnet MS/TP and LON. The table below shows the required communication card and software settings for each communication protocol.



Based on your selection, this manual will only contain the information you require.

Protocol	Communication card reference	Typical parameter settings in the controller	Interface file required?	Available settings
CAREL RS485		<pre>Supervision E17 BMS communication CAREL RS485 Baud rate 19200 Address 001</pre>	No	- Baudrate: 1200 to 19200 - Slave addresses: 1 to 207
Modbus RS485		<pre>Supervision E17 BMS communication Modbus RS485 Baud rate 19200 Address 001 Parity None Stop Bit 2</pre>	No	- Baudrate: 1200 to 19200 - Parity: None, Even or Odd - Nbr. stop bits: 1 or 2 - Slave addresses: 1 to 207
Modbus TCP/IP		<pre>Supervision E17 BMS communication Modbus IP</pre>	No	
Bacnet IP		<pre>Supervision E17 BMS communication Bacnet IP</pre>	No	

Protocol	Communication card reference	Typical parameter settings in the controller	Interface file required?	Available settings
Bacnet MS/TP			No	
LON			Yes (Xif and Nxe file)	

Communication table for Bacnet MS/TP

Variable	UOM	R/W	BACNET MS/TP		
			Obj_Type	Obj_Instance	Obj_Name
Condenser pressure	Bar	R	analog	1	A001
Ambient temperature	°C	R	analog	3	A003
AD switchpoint 1	°C	R/W	analog	4	A004
AD switchpoint 2	°C	R/W	analog	5	A005
Night quiet mode: AD switchpoint 1	°C	R/W	analog	8	A008
Night quiet mode: AD switchpoint 2	°C	R/W	analog	9	A009
Active setpoint	Bar	R	analog	10	A010
Regular setpoint	Bar	R/W	analog	11	A011
Free cooling setpoint	Bar	R/W	analog	12	A012
Proportional band	°C	R/W	analog	15	A015
Night quiet mode: daytime speed limit	%	R/W	analog	16	A016
Night quiet mode: night time speed limit	%	R/W	analog	17	A017
Daytime clock: Monday start hours	h	R/W	analog	1006	I006
Daytime clock: Monday start minutes	m	R/W	analog	1007	I007
Daytime clock: Monday end hours	h	R/W	analog	1008	I008
Daytime clock: Monday end minutes	m	R/W	analog	1009	I009
Daytime clock: Tuesday start hours	h	R/W	analog	1010	I010
Daytime clock: Tuesday start minutes	m	R/W	analog	1011	I011
Daytime clock: Tuesday end hours	h	R/W	analog	1012	I012
Daytime clock: Tuesday end minutes	m	R/W	analog	1013	I013
Daytime clock: Wednesday start hours	h	R/W	analog	1014	I014
Daytime clock: Wednesday start minutes	m	R/W	analog	1015	I015
Daytime clock: Wednesday end hours	h	R/W	analog	1016	I016
Daytime clock: Wednesday end minutes	m	R/W	analog	1017	I017
Daytime clock: Thursday start hours	h	R/W	analog	1018	I018
Daytime clock: Thursday start minutes	m	R/W	analog	1019	I019
Daytime clock: Thursday end hours	h	R/W	analog	1020	I020
Daytime clock: Thursday end minutes	m	R/W	analog	1021	I021
Daytime clock: Friday start hours	h	R/W	analog	1022	I022
Daytime clock: Friday start minutes	m	R/W	analog	1023	I023
Daytime clock: Friday end hours	h	R/W	analog	1024	I024
Daytime clock: Friday end minutes	m	R/W	analog	1025	I025



Variable	UOM	R/W	BACNET MS/TP		
			Obj_ Type	Obj_ Instance	Obj_ Name
Daytime clock: Saturday start hours	h	R/W	analog	1026	I026
Daytime clock: Saturday start minutes	m	R/W	analog	1027	I027
Daytime clock: Saturday end hours	h	R/W	analog	1028	I028
Daytime clock: Saturday end minutes	m	R/W	analog	1029	I029
Daytime clock: Sunday start hours	h	R/W	analog	1030	I030
Daytime clock: Sunday start minutes	m	R/W	analog	1031	I031
Daytime clock: Sunday end hours	h	R/W	analog	1032	I032
Daytime clock: Sunday end minutes	m	R/W	analog	1033	I033
Night quiet mode - Control type (0: clock - 1: via BMS)	---	R/W	analog	1034	I034
Integration time	sec	R/W	analog	1036	I036
Cleaning cycle: interval	days	R/W	analog	1037	I037
Cleaning cycle: duration	min	R/W	analog	1038	I038
AD ON fan speed	%	R/W	analog	1039	I039
AD OFF fan speed	%	R/W	analog	1040	I040
AD ON delay	sec	R/W	analog	1041	I041
AD OFF delay	sec	R/W	analog	1042	I042
Unit pLAN address	---	R	analog	1050	I050
Pre-cooling Deactivation function: start day	---	R/W	analog	1055	I055
Pre-cooling Deactivation function: start month	---	R/W	analog	1056	I056
Pre-cooling Deactivation function: end day	---	R/W	analog	1057	I057
Pre-cooling Deactivation function: end month	---	R/W	analog	1058	I058
Pre-cooling Deactivation function: start hour	h	R/W	analog	1059	I059
Pre-cooling Deactivation function: end hour	h	R/W	analog	1061	I061
Alarm delay	sec	R/W	analog	1067	I067
Sensor alarm delay	sec	R/W	analog	1068	I068
Fan speed	%	R	analog	1076	I076
EC fan N°2: actual speed	rpm	R	analog	1077	I077
EC fan N°2: maximum allowable speed	rpm	R	analog	1078	I078
EC fan N°2: actual power	W	R	analog	1079	I079
EC fan N°3: actual speed	rpm	R	analog	1081	I081
EC fan N°3: maximum allowable speed	rpm	R	analog	1082	I082
EC fan N°3: actual power	W	R	analog	1083	I083
EC fan N°4: actual speed	rpm	R	analog	1085	I085
EC fan N°4: maximum allowable speed	rpm	R	analog	1086	I086
EC fan N°4: actual power	W	R	analog	1087	I087
EC fan N°5: actual speed	rpm	R	analog	1089	I089
EC fan N°5: maximum allowable speed	rpm	R	analog	1090	I090
EC fan N°5: actual power	W	R	analog	1091	I091
EC fan N°6: actual speed	rpm	R	analog	1093	I093
EC fan N°6: maximum allowable speed	rpm	R	analog	1094	I094
EC fan N°6: actual power	W	R	analog	1095	I095
EC fan N°7: actual speed	rpm	R	analog	1097	I097
EC fan N°7: maximum allowable speed	rpm	R	analog	1098	I098
EC fan N°7: actual power	W	R	analog	1099	I099
EC fan N°8: actual speed	rpm	R	analog	1101	I101
EC fan N°8: maximum allowable speed	rpm	R	analog	1102	I102
EC fan N°8: actual power	W	R	analog	1103	I103
EC fan N°9: actual speed	rpm	R	analog	1105	I105
EC fan N°9: maximum allowable speed	rpm	R	analog	1106	I106
EC fan N°9: actual power	W	R	analog	1107	I107
EC fan N°10: actual speed	rpm	R	analog	1109	I109
EC fan N°10: maximum allowable speed	rpm	R	analog	1110	I110
EC fan N°10: actual power	W	R	analog	1111	I111

Variable	UOM	R/W	BACNET MS/TP		
			Obj_Type	Obj_Instance	Obj_Name
EC fan N°11: actual speed	rpm	R	analog	1113	I113
EC fan N°11: maximum allowable speed	rpm	R	analog	1114	I114
EC fan N°11: actual power	W	R	analog	1115	I115
EC fan N°12: actual speed	rpm	R	analog	1117	I117
EC fan N°12: maximum allowable speed	rpm	R	analog	1118	I118
EC fan N°12: actual power	W	R	analog	1119	I119
EC fan N°13: actual speed	rpm	R	analog	1121	I121
EC fan N°13: maximum allowable speed	rpm	R	analog	1122	I122
EC fan N°13: actual power	W	R	analog	1123	I123
EC fan N°14: actual speed	rpm	R	analog	1125	I125
EC fan N°14: maximum allowable speed	rpm	R	analog	1126	I126
EC fan N°14: actual power	W	R	analog	1127	I127
EC fan N°15: actual speed	rpm	R	analog	1129	I129
EC fan N°15: maximum allowable speed	rpm	R	analog	1130	I130
EC fan N°15: actual power	W	R	analog	1131	I131
Standard/Free cooling switch over (0: Standard / 1: Free cooling)	---	R/W	binary	1	D001
Free cooling status (0: OFF / 1: ON)	---	R	binary	2	D002
Night quiet mode (0: disable / 1: enable)	---	R/W	binary	4	D004
Night quiet mode status (0: not active / 1:active)	---	R	binary	5	D005
Night quiet mode: clock mode active (0: NO / 1: YES)	---	R	binary	6	D006
Night quiet mode: BMS mode active (0: NO / 1: YES)	---	R	binary	7	D007
Night quiet mode day/night time speedlimit via BMS (0: night / 1: day)	---	R/W	binary	8	D008
Run authorization (0: OFF / 1: ON)	---	R/W	binary	9	D009
Cleaning cycle (0: disable / 1: enable)	---	R/W	binary	10	D010
Pre-cooling deactivation function (0: disable / 1: enable)	---	R/W	binary	11	D011
NO1 relay output status - Alarm(s) (0:No Alarm / 1:Alarm)	---	R	binary	13	D013
NO2 relay output status- Warning(s) (0:No Warning / 1:Warning)	---	R	binary	14	D014
NO3 relay output status- RH pre-cooler (0:open / 1:closed)	---	R	binary	15	D015
NO4 relay output status - LH pre-cooler (0:open / 1:closed)	---	R	binary	16	D016
NO6 relay output status - Run indication (0:Stopped / 1:Running)	---	R	binary	18	D018
B6 Dig In status - Free cooling mode (0: Disabled / 1: Enabled)	---	R	binary	21	D021
ID1 (0: Off / 1:On) - Remote start/stop status	---	R	binary	22	D022
Alarm sensor B1 (fluid outlet temperature sensor)	---	R	binary	24	D024
Fan N°2 - alarm/warning present	---	R	binary	29	D029
Fan N°3 - alarm/warning present	---	R	binary	30	D030
Fan N°4 - alarm/warning present	---	R	binary	31	D031
Fan N°5 - alarm/warning present	---	R	binary	32	D032
Fan N°6 - alarm/warning present	---	R	binary	33	D033
Fan N°7 - alarm/warning present	---	R	binary	34	D034
Fan N°8 - alarm/warning present	---	R	binary	35	D035
Fan N°9 - alarm/warning present	---	R	binary	36	D036
Fan N°10 - alarm/warning present	---	R	binary	37	D037
Fan N°11 - alarm/warning present	---	R	binary	38	D038
Fan N°12 - alarm/warning present	---	R	binary	39	D039
Fan N°13 - alarm/warning present	---	R	binary	40	D040
Fan N°14 - alarm/warning present	---	R	binary	41	D041
Fan N°15 - alarm/warning present	---	R	binary	42	D042



Variable	UOM	R/W	BACNET MS/TP		
			Obj_ Type	Obj_ Instance	Obj_ Name
Alarm present	---	R	binary	59	D059
Unit status (0: OFF / 1: ON)	---	R	binary	63	D063
Warning present	---	R	binary	66	D066
Alarm sensor B4 (ambient temperature sensor)	---	R	binary	67	D067



More information

REFERENCE LITERATURE

- Eurovent 9-5 (6) Recommended Code of Practice to keep your Cooling System efficient and safe. Eurovent/Cecomaf, 2002, 30p.
- Guide des Bonnes Pratiques, Legionella et Tours Aéroréfrigérantes. Ministères de l'Emploi et de la Solidarité, Ministère de l'Economie des Finances et de l'Industrie, Ministère de l'Environnement, Juin 2001, 54p.
- Voorkom Legionellose. Ministerie van de Vlaamse Gemeenschap. December 2002, 77p.
- Legionnaires' Disease. The Control of Legionella Bacteria in Water Systems. Health & Safety Commission. 2000, 62p.
- Hygienische Anforderungen an raumluftechnische Anlagen. VDI 6022.

INTERESTING WEBSITES

Baltimore Aircoil Company	www.BaltimoreAircoil.com
BAC Service website	www.BACservice.eu
Eurovent	www.eurovent-certification.com
European Working Group on Legionella Infections (EWGLI)	EWGLI
ASHRAE	www.ashrae.org
Uniclimate	www.uniclimate.fr
Association des Ingénieurs et techniciens en Climatique, Ventilation et Froid	www.aicvf.org
Health and Safety Executive	www.hse.gov.uk

ORIGINAL DOCUMENTATION

 This manual is originally made in English. Translations are provided for your convenience. In the event of discrepancies, the English original text shall prevail over the translation.

The service expert for BAC equipment

We offer tailored services and solution for BAC cooling towers and equipment.

- Original spare parts and fill -for an efficient, safe and year round reliable operation.
- Service solutions - preventive maintenance, repairs, refurbishments, cleaning and disinfection for reliable trouble-free operation.
- Upgrades and new technologies - save up energy and improve maintenance by upgrading your system.
- Water treatment solutions - equipment for controlling corrosion scaling and proliferation of bacteria.

For more details, contact your local BAC representative for further information and specific assistance at www.BACservice.eu



A series of horizontal dotted lines for writing, spanning the width of the page.



A series of horizontal dotted lines spanning the width of the page, providing a template for writing or drawing.





A series of horizontal dotted lines for writing, spanning the width of the page.



A series of horizontal dotted lines spanning the width of the page, providing a template for handwritten notes or a checklist.





A series of horizontal dotted lines for writing, spanning the width of the page.



A series of horizontal dotted lines spanning the width of the page, providing a template for writing or data entry.



COOLING TOWERS

CLOSED CIRCUIT COOLING TOWERS

ICE THERMAL STORAGE

EVAPORATIVE CONDENSERS

HYBRID PRODUCTS

PARTS, EQUIPMENTS & SERVICES

BLUE by nature
GREEN at heart



www.BaltimoreAircoil.com

Europe@BaltimoreAircoil.com

Please refer to our website for local contact details.

Industriepark - Zone A, B-2220 Heist-op-den-Berg, Belgium

© Baltimore Aircoil International nv